

ASCO™ SOLENOID VALVE

2/2 NORMALLY CLOSED – PILOT OPERATED - G3/8 - G1/2

SERIES
L182-D05

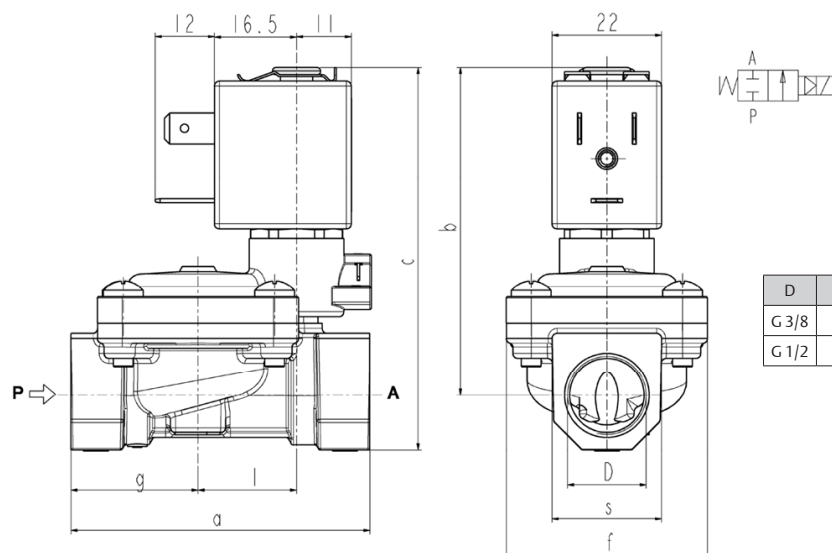

General Features

Diaphragm valve, pilot operated, having full orifice.

Suitable to shut off liquid and gaseous fluids (verify the compatibility of fluid with material in contact).

Technical Features	
Maximum allowable pressure (PS)	20 bar
Response times	3/8 1/2
Opening time (ms)	70
Closing time (ms)	670
Fluid temperature	-10°C +140°C*
Max viscosity	5°E (~37 cStokes or mm²/s)

* Maximum operating temperature 85°C in compliance with WRAS approval

Materials in Contact with Fluid	
Body	Chemically nickel coated brass (Ni-P)
Sealing	EPDM
Internal components	Brass and stainless steel
Seat	Chemically nickel coated brass (Ni-P)
Core tube	Stainless steel
Shading coil	Copper

Coil	ZB10A	ZB12A
Approval	/	UL and CSA
Encapsulation material	PA fiberglass reinforced	PET fiberglass reinforced
Insulation class	F (155°C)	F (155°C)
Ambient temperature	-10°C +60°C	-10°C +60°C
Continuous duty	ED 100%	
Electric connection	DIN 46340 - 3 poles plug connector	
Protection degree	IP 65 (EN 60529) with plug connector	IP 67 (EN 60529) with plug connector
Voltages	DC	12-24V (+10% -5%)
	AC	24V/50-60Hz - 115V/50Hz - 230V/50-60Hz (+10% -15%) (Other voltages and frequencies on request)

Port size ISO 228	Orifice size (mm)	Differential pressure (bar)				Kv (m³/h)	Series and type		Power absorption				Sealings	Notes	Weight (kg)
		Δp min	Δp max		Valve		Coil	AC (VA)		DC					
			Gases	Liquids				Inrush	Holding						
3/8	13,5	0,35	AC	DC	AC	DC	L182D05	ZB10A ZB12A	VA	VA	W	W	EPDM	1-2	0,32
1/2			16	16	16	16			12	6	4	5,5			0,38

Notes

- Sealings: EPDM=Ethylene-propylene elastomer (WRAS/KTW certified compound)
 - Operation with gaseous media, at high pressure without any outlet restriction, can reduce the diaphragm life.
- 1 - Low power consumption coil on request (3,5 VA in AC – 3W in DC): Δp max = 12 bar
 2 - approved solenoid valve (certificate n. 2007001).

ASCO™

www.Emerson.com/asco

BCAE
Industrial Automation

青岛秉诚自动化设备有限公司
地址：中国·青岛市重庆南路99号海尔云街甲3号楼7F

服务热线：4006-918-365
网址：http://www.asco.store

传真：(86-532)585-10-365
Email：sales@bechinas.com

SERIES
L182-D05

ASCO™ SOLENOID VALVE
2/2 NORMALLY CLOSED – PILOT OPERATED - G3/8 - G1/2

Spare Parts

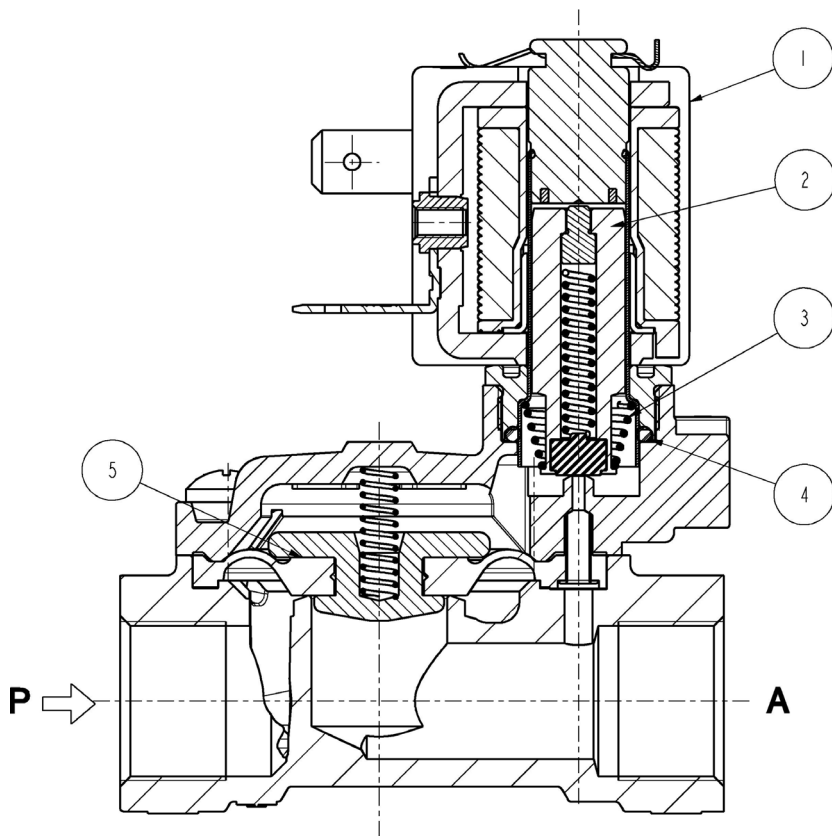

Kit description	Kit P.N.	Consisting of:
Core kit	G3138202	Core kit pos.2 Core return spring pos. 3 O-Ring guide assembly pos. 4
Diaphragm assembly	2844308R	Diaphragm assembly pos.5
Coil	ZB10 ZB12	Coil pos.1

Installation

- Solenoid valve can be mounted in any position; vertical with coil upwards preferred.

THE VALIDITY OF REPORTED DATA IS REFERRED TO THE DATE OF ISSUE. POSSIBLE UPDATES ARE AVAILABLE ON REQUEST