

ASCO™ SOLENOID VALVE

2/2 NORMALLY CLOSED – PILOT OPERATED - 3/8 NPT ÷ 1 NPT

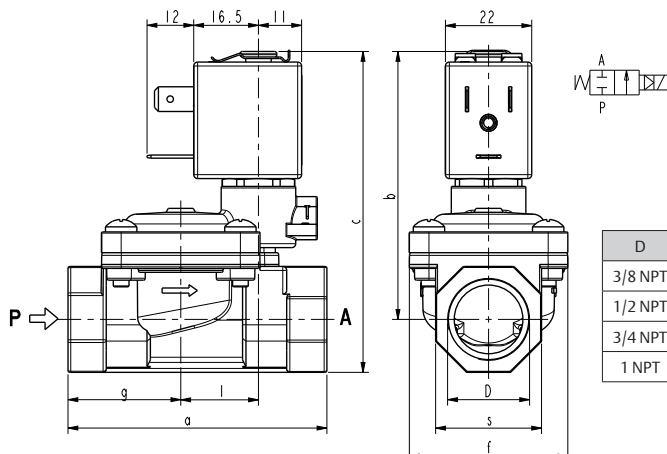

General Features

Diaphragm valve, pilot operated, having full orifice.

Suitable to shut off liquid and gaseous fluids (verify the compatibility of fluid with material in contact).

Technical Features				
Maximum allowable pressure (PS)	20 bar			
Response times	3/8	1/2	3/4	1
Opening time (ms)	70	70	70	90
Closing time (ms)	670	600	500	420
Fluid temperature	-10°C +90°C (NBR) 0°C +130°C (FPM) -10°C +140°C (EPDM)* WRAS			
Max viscosity	5"E (~37 cStokes or mm²/s)			

* Maximum operating temperature 85°C in compliance with WRAS approval

Materials in Contact with Fluid	
Body	Stainless steel AISI 316L
Sealing	NBR or FPM or EPDM
Internal components	Stainless steel
Seat	Stainless steel AISI 316L
Core tube	Stainless steel
Shading coil	Copper

Coil	ZB12A	ZB14A
Approval	UL and CSA	
Encapsulation material	PET fiberglass reinforced	
Insulation class	F (155°C)	H (180°C)
Ambient temperature	-10°C +60°C	-10°C +75°C
Continuous duty	ED 100%	
Electric connection	DIN 46340 - 3 poles plug connector	
Protection degree	IP 67 (EN 60529) with plug connector	
Voltages	DC	12-24V (+10% -5%)
	AC	24V/50-60Hz - 115V/50Hz - 230V/50-60Hz (+10% -15%) (Other voltages and frequencies on request)

On request	ZB12Y	ZB14Y
Approval	UL	
Voltages	AC	220-230V/50Hz 208-240V/60Hz (+10% -15%)

Port size NPT	Orifice size (mm)	Differential pressure (bar)				Kv (m³/h)	Series and type			Power absorption				Sealings	Notes	Weight (kg)
		Δp min	Δp max		Valve		Valve with manual override	Coil	AC (VA)		DC					
			Gases	Liquids					Inrush VA	Holding VA		W	W			
3/8	13,5	0,35	16	16	16	16	L182(*)11	L182(*)12	ZB12A	12	6	4	5,5	(*) = B (NBR) (*) = V (FPM) (*) = D (EPDM)	1-3	2,5
1/2			(12)	(12)	(12)	(12)										3,8
3/4	18		12	12	12	12										5
1	24		(10)	(10)	(10)	(10)										12

Notes

- Sealings: B(NBR) = Nitrile-butylene elastomer V(FPM) = Fluoro-carbon elastomer D(EPDM)=Ethylene-propylene elastomer (WRAS/KTW certified compound)
 - Operation with gaseous media, at high pressure without any outlet restriction, can reduce the diaphragm life.
 - On request coil in class H (ZB14A – see § "COIL")
 - The bracketed values of Δp max are related to valves with FPM seals.
- Low power consumption coil on request ZB12C or ZB14C (3,5 VA in AC – 3W in DC): Δp max = 12 bar
 - Low power consumption coil on request ZB12C or ZB14C (3,5 VA in AC – 3W in DC): Δp max = 8 bar
 - WRAS approved solenoid valve (certificate n. 2007001).

STAINLESS STEEL

SERIES

L182-NPT

ASCO™ SOLENOID VALVE
2/2 NORMALLY CLOSED – PILOT OPERATED - 3/8 NPT ÷ 1 NPT

Spare Parts

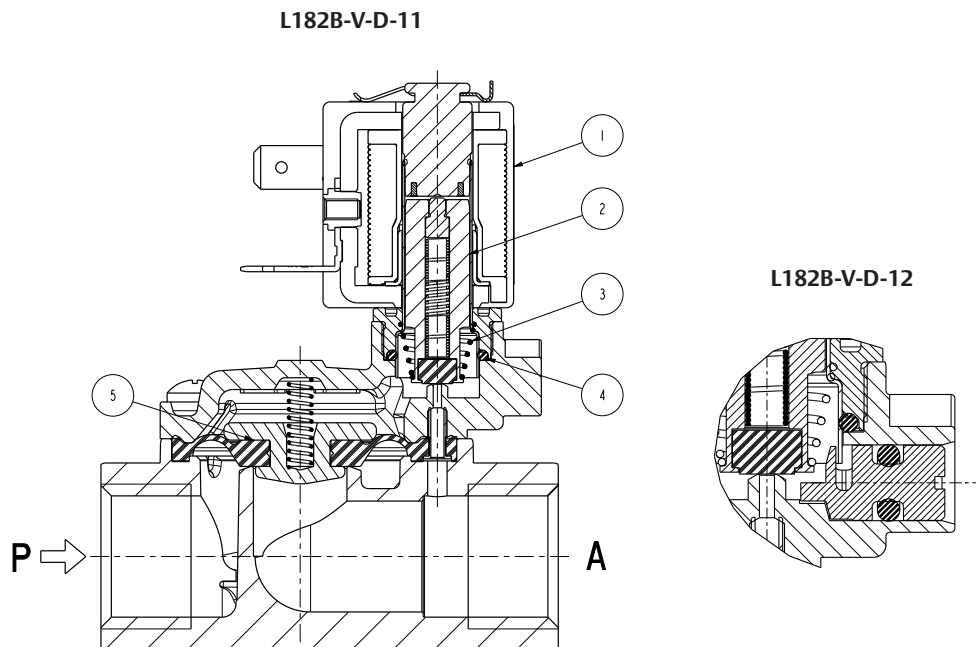

Kit description	Model	Port Size	Kit P.N.	Consisting of:
Core kit	L182B-V		G3138201	Core kit pos.2
	L182D		G3138202	Core return spring pos. 3 O-Ring guide assembly pos. 4
Diaphragm assembly	L182B	3/8-1/2	2844305R	Diaphragm assembly pos.5
		3/4	298594-003R	
		1	298592-003R	
	L182V	3/8-1/2	2844309R	
		3/4	298594-001R	
		1	298592-001R	
	L182D	3/8-1/2	2844308R	
		3/4	298594-002R	
		1	298592-002R	
Coil		ZB12 ZB14	Coil pos.1	

Installation

- Solenoid valve can be mounted in any position; vertical with coil upwards preferred.

THE VALIDITY OF REPORTED DATA IS REFERRED TO THE DATE OF ISSUE. POSSIBLE UPDATES ARE AVAILABLE ON REQUEST

ASCO™

www.Emerson.com/asco



青岛秉诚自动化设备有限公司
地址：中国·青岛市重庆南路99号海尔云街甲3号楼7F

服务热线：4006-918-365
网址：http://www.asco.store

传真：(86-532)585-10-365
Email：sales@bechinas.com