

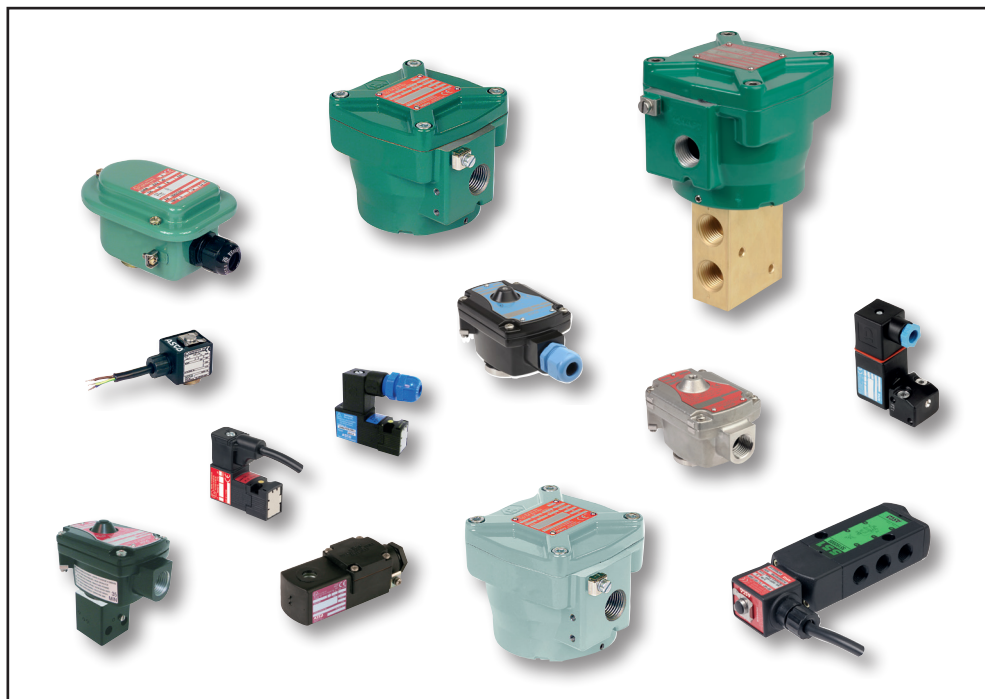







EXPLOSIONPROOF SOLENOIDS

Product Index

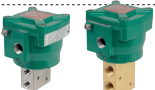

Function	Description	Pipe connections	Series	Page
 	Hazardous areas			IV-V
	Identification			VI
	Equipment groups and temperature classes / Certificates - Products			VII-VIII
	Standards (CENELEC - CEN standards)			
	Types of protection		see section: «General & Engineering Information»	www.asco.com
Ex d (flameproof), ATEX-IECEx:				
3/2	• Operators, aluminium (LPKF) or stainless steel (WSPKF) II2G Ex d IIB+H2 Gb T6..T4, II2D Ex tb IIIC Db IP66/IP67		 LPKF WSPKF	1
2/2	• Operators, aluminium (NF) or stainless steel (WSNF) II 2G Ex db IIC T6..T4 Gb, II 2D Ex tb IIIC Db IP66/67		 NF/WSNF	3
3/2 NC	• Solenoid valves, direct operated, aluminium body, with LPKF type operator II2G Ex d IIB+H2 Gb T6..T4, II2D Ex t IIIC Db IP67	ISO 15218 (CNOMO, size 30)	 314	5
3/2 NC-5/2-5/3 NAMUR	• Solenoid valves, pilot operated, aluminium body (LPKF-WSPKF-NF-WSNF-374/NK)	1/4-1/2	 551-553	3/2 5/2-5/3 NAMUR
3/2 NC-5/2 NAMUR	• Solenoid valves, pilot operated, brass body (LPKF-WSPKF-NF-WSNF)	1/4	 551	3/2 5/2 NAMUR
3/2 NC-5/2-5/3 NAMUR	• Solenoid valves, pilot operated, stainless steel body (LPKF-WSPKF-NF-WSNF-314/LPKF)	1/4-1/2	 551-553	3/2 5/2-5/3 NAMUR
3/2 U	• Solenoid valves, direct operated, brass or stainless steel body II 2 G Ex d IIC Gb T6..T4, II 2 D Ex tb IIIC Db IP67	1/4-1/2 (NPT)	 327⁽¹⁾	Process Industry

⁽¹⁾ [WSCR / WSCEM / WSCRIS](#)



00128GB-2018/R01
Availability, design and specifications are subject to change without notice. All rights reserved.

All leaflets are available on: www.asco.com









青岛秉诚自动化设备有限公司
地址：中国·青岛市重庆南路99号海尔云街甲3号楼7F

服务热线：4006-918-365
网址：<http://www.asco.store>

Explosionproof equipment - I
传真：(86-532)585-10-365
Email：sales@bechinas.com

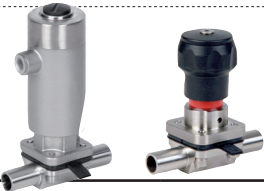
Function	Description	Pipe connections	Series	Page
Ex m (encapsulated), ATEX-IECEX:				
2/2-3/2	<ul style="list-style-type: none"> Operators, moulded coil (EM5-MXX) II 2G Ex mb IIC T5..T3 Gb, II 2D Ex mb IIIC 100°C..200°C Db IP67 		PV	7
3/2 NC-5/2-5/3 NAMUR	<ul style="list-style-type: none"> Solenoid valves, pilot operated, aluminium body (PV) 	1/4-1/2	551-553	3/2 5/2-5/3 NAMUR
3/2 NC-5/2 NAMUR	<ul style="list-style-type: none"> Solenoid valves, pilot operated, brass body (PV) 	1/4	551	3/2 5/2 NAMUR
3/2 NC-5/2-5/3 NAMUR	<ul style="list-style-type: none"> Solenoid valves, pilot operated, stainless steel body (PV) 	1/4-1/2	551-553	3/2 5/2-5/3 NAMUR
Ex e mb (increased safety/encapsulated), ATEX-IECEX:				
3/2	<ul style="list-style-type: none"> Operator, increased safety/encapsulated II 2G Ex e mb IIC T4 Gb, II 2D Ex tb IIIC T135°C Db IP67 		WBLP	9
2/2-3/2	<ul style="list-style-type: none"> Operators, increased safety/encapsulated (M6-MXX-M12) II 2G Ex e mb IIC T6..T3 Gb, II 2D Ex tb IIIC T85°C..T200°C Db IP66/67 		EM/WSEM	11
3/2 NC-5/2-5/3 NAMUR	<ul style="list-style-type: none"> Solenoid valves, pilot operated, aluminium body (EM/WSEM) 	1/4-1/2	551-553	3/2 5/2-5/3 NAMUR
3/2 NC-5/2 NAMUR	<ul style="list-style-type: none"> Solenoid valves, pilot operated, brass body (EM/WSEM) 	1/4	551	3/2 5/2 NAMUR
3/2 NC-5/2-5/3 NAMUR	<ul style="list-style-type: none"> Solenoid valves, pilot operated, stainless steel body (EM/WSEM) 	1/4-1/2	551-553	3/2 5/2-5/3 NAMUR
Ex ia (intrinsically safe), ATEX-IECEX:				
3/2	<ul style="list-style-type: none"> Operator, aluminium (LI) II 1G Ex ia IIC T6 Ga, II 2D Ex tb IIIC T85°C IP66/IP67 Db Operator, stainless steel (WSLI) II 1G Ex ia IIC T6 Ga, II 2D Ex tb IIIC T85°C IP66/IP67 Db 		LI WSLI	13
3/2 NC	<ul style="list-style-type: none"> Solenoid valves, direct operated, plastic body, pad mount, ISO 15218 (CNOMO, size 15) II 1 G Ex ia IIC T6..T4 Ga, II 1 D Ex ia IIIC T85°C .. T135°C IP65 Da 		302	15
3/2 NC	<ul style="list-style-type: none"> Solenoid valves, direct operated, aluminium body, pad mount, ISO 15218 (CNOMO, size 30) II 1G Ex ia IIC T6 Ga, II 2D Ex ib IIIC T85°C Db IP67 		195/LISC	19
3/2 NC	<ul style="list-style-type: none"> Solenoid valves, direct operated, brass or stainless steel body II 2G Ex ia IIC T6 Gb, II 2D Ex tb IIIC T85°C Db IP66/67 	1/4	327	NFIS WSNFIS
3/2 NC-5/2-5/3 NAMUR	<ul style="list-style-type: none"> Solenoid valves, pilot operated, aluminium body (LI-302-195/LISC-630/piezotronic) 	1/4-1/2	551-553	3/2 5/2-5/3 NAMUR
3/2 NC-5/2 NAMUR	<ul style="list-style-type: none"> Solenoid valves, pilot operated, brass body (LI-WSLI-302-630/piezotronic) 	1/4	551	3/2 5/2 NAMUR
3/2 NC-5/2-5/3 NAMUR	<ul style="list-style-type: none"> Solenoid valves, pilot operated, stainless steel body (LI-WSLI-195/LISC) 	1/4-1/2	551-553	3/2 5/2-5/3 NAMUR
Ex nA (non-sparking protection), ATEX:				
2/2 NC 3/2 NC-NO-U	<ul style="list-style-type: none"> Solenoid valves, direct operated, plastic body, pad mount, ISO 15218 (CNOMO, size 15) II 3G Ex nA IIC T6..T4 Gc, II 3D Ex tc IIIC IP65 T85°C..T135°C Dc 		302	23

Function	Description	Pipe connections	Series	Page	
<i>Dust applications, ATEX:</i>					
	<i>moulded coils types with connectors</i>				
	II 3 D Ex tc IIIC T115°C/T110°C Dc IP65X		SG	25	
<i>Constructional safety ATEX:</i>					
3/2 NC-5/2-5/3 NAMUR	• Air operated valves, aluminium body II 2GD IIB or IIC	1/4-1/2		551-553	3/2 5/2-5/3 NAMUR
3/2 NC-5/2 NAMUR	• Air operated valves, stainless steel body II 2GD IIB or IIC	1/4-1/2		551-553	3/2 5/2 NAMUR
2/2 - 3/2	• Pressure operated valves II 2 GD c IIB T4 T135°C / II 2 D c T135°C II 3 GD c T4 T135°C			290/390	Pressure Operated Valves [2/2 (www.asco.com) - 3/2 (www.asco.com)]
2/2 - 3/2	• Pressure operated valves II 2 GD c x°C (Tx)			298/398	Pressure Operated Valves [2/2 (www.asco.com) - 3/2 (www.asco.com)]
2/2 - 3/2	• Pressure operated valves II 2 GD c T6			287/387	Pressure Operated Valves [2/2 (www.asco.com) - 3/2 (www.asco.com)]
2/2 - 3/2	• Pressure operated valves II 2 GD c T6 T85°C / II 3 GD c T85°C X			AD	Pressure Operated Valves [2/2 (www.asco.com) - 3/2 (www.asco.com)]
2/2	• Pressure or manual operated diaphragm aseptic valves II 2 GD c K IIB			Steripur KMA KMD	Biotechnology & Pharmaceutical Catalogue
<i>Other types of protection and national standards:</i>					
2/2-3/2	• Operators, encapsulated, NEMA (EF)			EF	EF/EV
<i>Accessories:</i>					
	• Cable glands, ATEX			882	27

00128GB-2018/R01
Availability, design and specifications are subject to change without notice. All rights reserved.

All leaflets are available on: www.asco.com

SOME HISTORY

The classification of hazardous areas into zones established the level of protection required for electrical equipment installed in explosive gas and dust atmospheres.

The two following standards define the areas:

IEC-EN 60079-10-1: Classification of areas, explosive gas atmospheres

IEC-EN 60079-10-2: Classification of areas, combustible dust atmospheres

The selection and construction of electrical installations is defined by standard IEC-EN 60079-14.

DEFINITION OF A PLACE WHERE A POTENTIALLY EXPLOSIVE ATMOSPHERE MAY OCCUR

The classification of an installation into distinct zones has two objectives (according to ATEX 1999/92/EC):

- To define the categories of equipment used in the zones indicated, provided they are suitable for gases, vapours or mists and/or dusts.
- To classify hazardous places into zones to prevent ignition sources and be able to select the correct electrical and non-electrical equipment accordingly. The zones are defined on the basis of the occurrence of explosive gaseous or dusty atmospheres.

GAS GROUPS

Group II : Equipment intended for use in places with an explosive gas atmosphere other than mines susceptible to firedamp.

Group I : Equipment intended for use in mines susceptible to firedamp.

	Zone	Category (ATEX 2014/34/EU)	Presence of explosive atmospheres
Group II	zone 0	1 G ⁽¹⁾	Continuous, frequent or for long periods
	zone 1	2 G	Intermittent in normal operation (likely)
	zone 2	3 G	Occasional or for short periods (never in normal operation)
Group I (mines)		M1 ⁽¹⁾	Presence (methane, dust)
		M2	Risk of presence (methane, dust)

DUST GROUPS (IEC 60079-0)

Group III : Equipment intended for use in places with an explosive dust atmosphere other than mines susceptible to firedamp.

	Zone	Category (ATEX 2014/34/EU)	Presence of explosive atmospheres
Group III	zone 20	1 D ⁽¹⁾	Continuous, frequent or for long periods (air/cloud of combustible dust)
	zone 21	2 D	Intermittent in normal operation
	zone 22	3 D	Occasional or for short periods

The classification of the installation is **the responsibility of the user**. He must individually evaluate each installation to determine the differences between them.

Separate assessments must be made for places with potentially explosive atmospheres caused by gases or vapours and for those caused by dusts.

EQUIPMENT PROTECTION LEVELS - EPLs

In normal circumstances the effect of the EPLs will be to retain the normal zone/equipment protection relationship. If, however, the risk is considered especially severe, then the required EPL for the zone may be increased. Similarly, if the risk is deemed to be especially small or negligible, the EPL may be reduced from the norm.

The following table shows the normal relationship between EPL and zone/category (without supplementary risk assessment).

Equipment Protection Level (EPL)	Normal Applicable Zone(s)	Category (2014/34/EU)
Ga	0 (and 1 and 2)	1G
Gb	1 (and 2)	2G
Gc	2	3G
Da	20 (and 21 and 22)	1D
Db	21 (and 22)	2D
Dc	22	3D
Ma / Mb	mines	M1 / M2

⁽¹⁾ G = gas ; D = dust ; M = mines

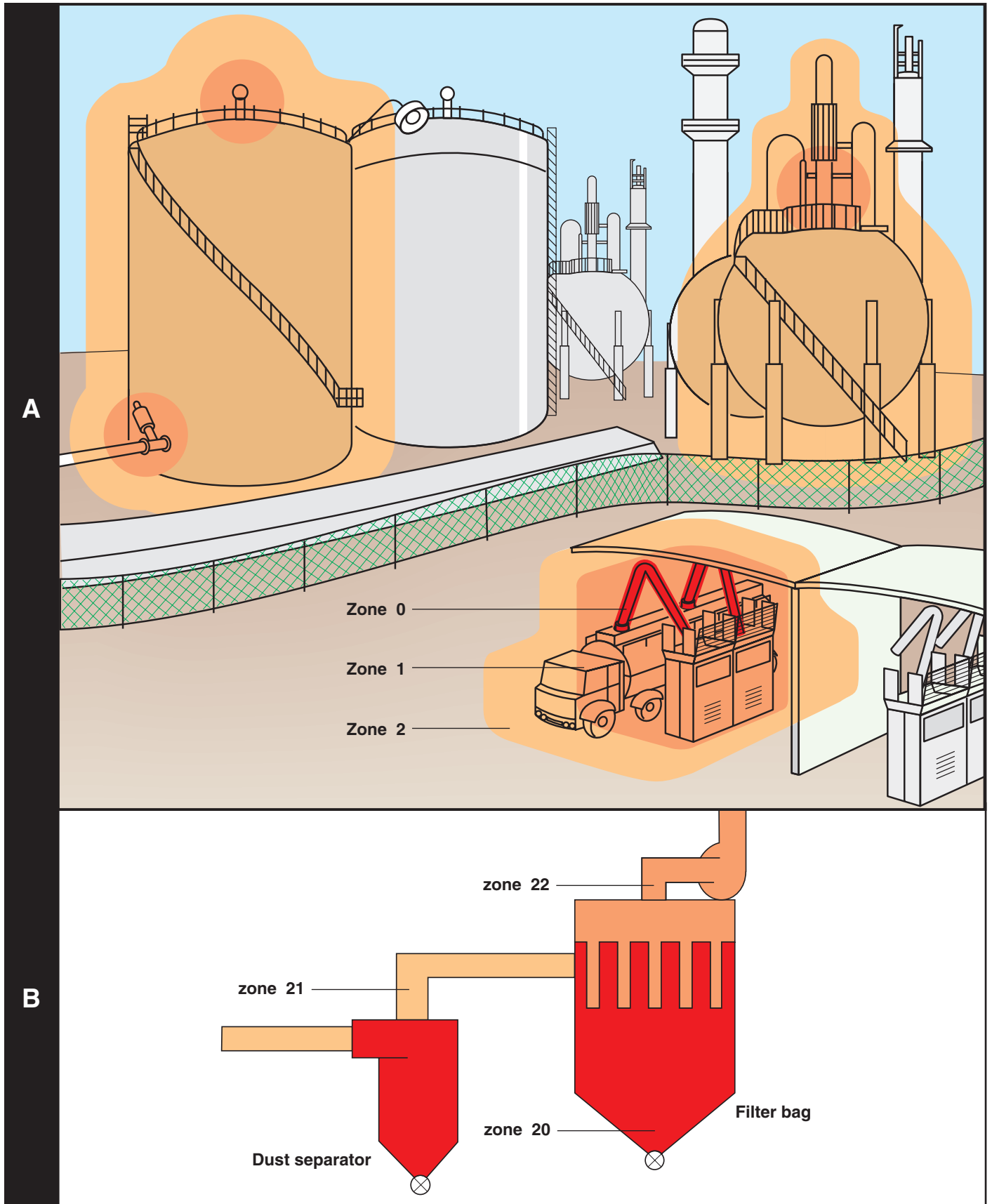

EXAMPLES OF A CLASSIFICATION INTO ZONES

Drawing **A** of an explosive atmosphere caused by gas:

Drawing **B** of an explosive atmosphere caused by dust:



Above drawings **A** and **B** are an example only and must not be used as a model for an actual plant whose design is, in every case, the responsibility of the constructor and operator.

00129GB-2017/R01
Availability, design and specifications are subject to change without notice. All rights reserved.

All leaflets are available on: www.asco.com

HOW CAN ATEX, EN-IEC 60079-0 OR EN 13463-1 APPROVED APPARATUS FOR USE IN EXPLOSIVE ATMOSPHERES BE IDENTIFIED?

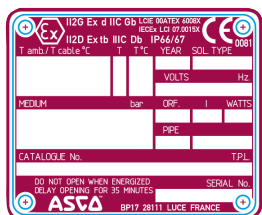
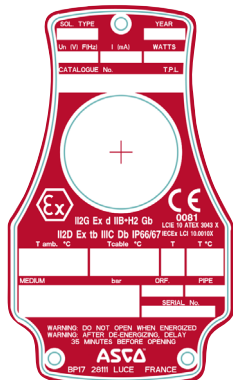
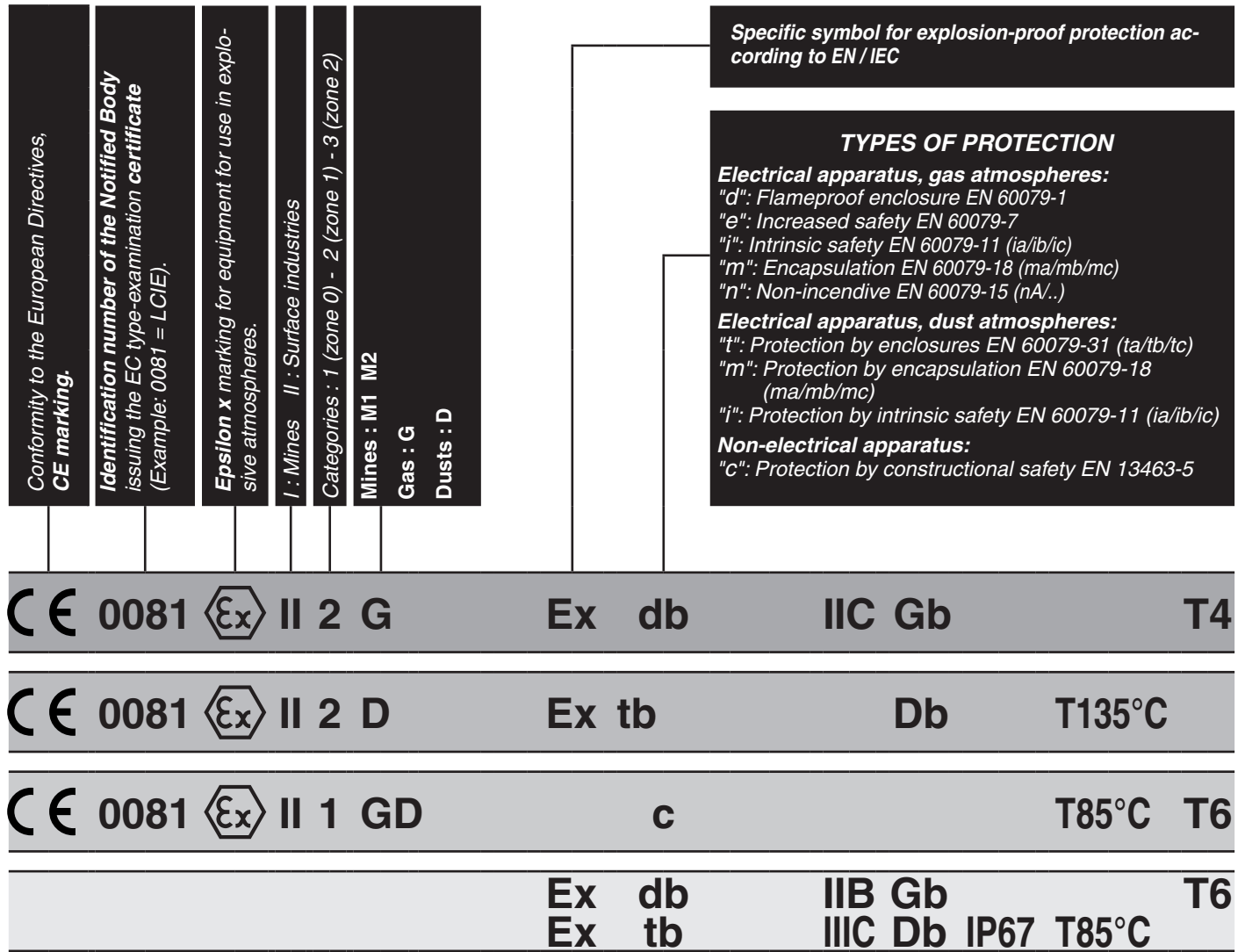

ma or ia = for use in zone 0 gas (D = Dusts)
mb or ib = for use in zone 1 gas (D = Dusts)

Equipment groups (IIA, IIB, IIC, IIIA, IIIB, IIIC)

Maximum surface temperature

Temperature class

Enclosure ingress protection (IP) rating for dust (EN 60529)

Equipment Protection Level (EPL)

CLASSIFICATION OF GASES INTO EXPLOSION GROUPS

Group I : Electrical equipment intended for use in the underground parts of mines, and to those parts of surface installations of such mines, likely to become endangered by firedamp and/or combustible dust.

Group II : Electrical equipment intended for use in other places likely to become endangered by explosive atmospheres (surface industries).

For the types of protection "d" and "i", group II is subdivided into IIA, IIB, IIC. Electrical apparatus certified for IIB may be used in applications requiring apparatus to be certified for group IIA. Electrical apparatus certified for IIC may be used in applications requiring apparatus to be certified for groups IIA and IIB.

For example the "d" and "i" types of protection are respectively subdivided according to the Maximum Experimental Safe Gap (MESG) and to the Minimum Igniting Current (MIC).

Electrical apparatus certified for IIB may be certified for use with a gas belonging to group IIC. In this case, the identification is supplemented with the chemical symbol or the name of the gas (example: Ex d IIB + H₂ according to EN 60079-0 and EN 60079.1).

The table below indicates the groups to which some gas mixtures belong:

Groups	Gas	Ignition temperature ⁽¹⁾ (°C)	Temperature class						
			T1	T2	T3	T4	T5	T6	
I	methane (firedamp)								
II	A	acetone	540	•					
		acetic acide	485	•					
		ammonia	630	•					
		ethane	515	•					
		methylene chloride	556	•					
		methane (CH ₄)	537	•					
	B	carbon monoxyde	605	•					
		propane	470	•					
		n-butane	365		•				
		n-butyl	370		•				
		n-hexane	240			•			
		acetaldehyde	140				•		
	C	ethyl ether	160				•		
		ethyl nitrite	90						•
		ethylene	425		•				
B	ethyl oxyde	429-440		•					
	hydrogen sulfide	270			•				
	acetylene (C ₂ H ₂)	305		•					
C	carbon disulphide (CS ₂)	102						•	
	hydrogen (H ₂)	560	•						

⁽¹⁾ Temperature of a hot surface able to ignite a gas mixture.

The ignition temperature of the gas mixture must be higher than the maximum surface temperature. In practice, a 10 to 20% safety margin is observed between the ignition temperature and the rated nameplate temperature.

The ignition temperature of a cloud of dust is generally between 300 and 700°C. At 150 to 350°C, the ignition temperature of a layer of dust is far below that of a dust cloud. A burning dust layer can initiate a dust explosion if brought in contact with a combustible dust cloud, so these values must be taken into account to limit the risk.

TEMPERATURE CLASS

The temperature classification is based on the maximum surface temperature of equipment. That is the highest temperature any part of or the entire surface of an electrical device can reach under the most unfavourable operating conditions capable of igniting a surrounding explosive atmosphere.

Group I : Temperature ≤ 150°C or ≤ 450°C according to coal dust accumulation on equipment

Group II : Equipment must be classified and marked:

- preferably with the temperature class (T classification)
- defined by the surface temperature or,
- limited to the specified flammable gases or dusts for which it is approved, if necessary (and marked accordingly).

Temperature class	Maximum surface temperature (°C)	Ignition temperature ⁽¹⁾ (°C)
T1	450	> 450
T2	300	> 300
T3	200	> 200
T4	135	> 135
T5	100	> 100
T6	85	> 85

CLASSIFICATION OF DUSTS INTO EXPLOSION GROUPS (IEC 60079-0)

Group III : Electrical equipment intended for use in places with an explosive dust atmosphere other than mines susceptible to firedamp.

Group III is subdivided into **IIIA** (combustible flyings), **IIIB** (non-conductive dust) and **IIIC** (conductive dust).

Combustible dust: Finely divided solid particles, 500 µm or less in nominal size, which may be suspended in air, may settle out of the atmosphere under their own weight, may burn or glow in air, and may form explosive mixtures with air at atmospheric pressure and normal temperatures.

Non-conductive dust: Combustible dust with electrical resistivity greater than $10^3 \Omega.m$

Conductive dust: Combustible dust with electrical resistivity equal to or less than $10^3 \Omega.m$

Combustible dust	Ignition temperature ⁽¹⁾ (°C)	Self-ignition temperature of dust layers ⁽¹⁾ (°C)
Starch	440	290
Aluminium	530	280
Cotton	560	350
Cereals	420	290
Magnesium	610	410
Soybean	500	245
Sulphur	280	280
Tabacco	450	300

- ⁽¹⁾ The maximum surface temperature must be identified and suitable for the specified type of dust present (equipment marked for zone 21). In order to prevent the ignition of dusty atmospheres, the maximum surface temperature needs to be limited. It must not exceed:
- 2/3 of the auto-ignition temperature of the specified **cloud of dust**,
 - the auto-ignition temperature of a 5 mm **layer of dust** minus 75°C.

TYPE EXAMINATION CERTIFICATES

SELECTION OF PRODUCTS

available at "www.asco.com"

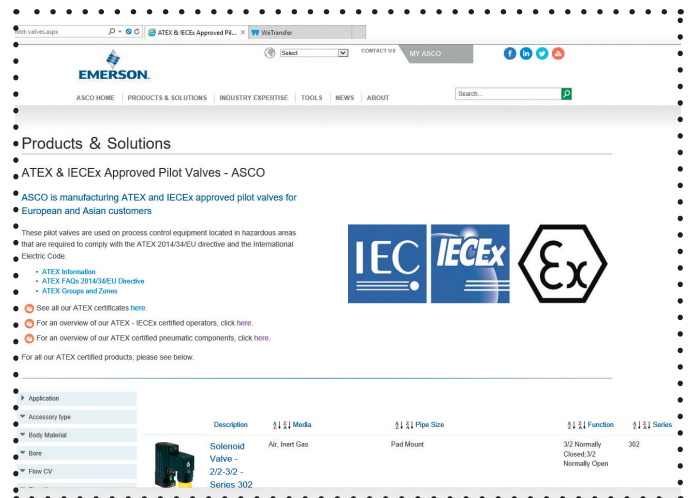
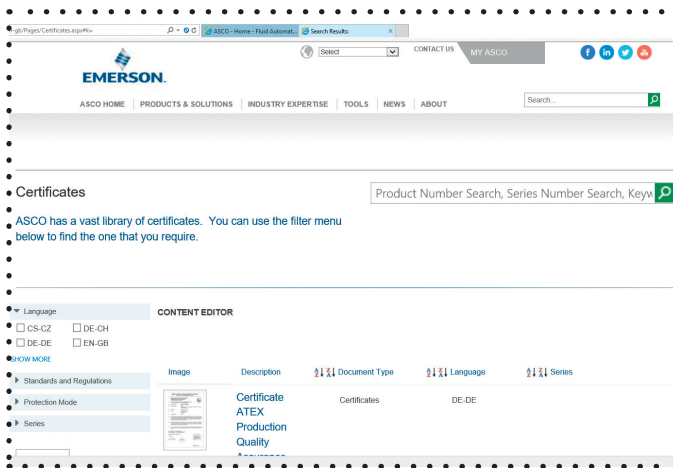

Certificates issued by the IECEx Certified Equipment Program are issued as "Electronic Certificates" and are live on the IECEx Website. This enables full public access for viewing and printing. Visit the IECEx "On-Line Certificate" System.

FEATURES

- Explosionproof operator for use in potentially explosive atmospheres according to ATEX-Directive 2014/34/EU
EC type examination certificate no.: **LCIE 10 ATEX 3043X**
IECEX Certificate of Conformity no.: **IECEX LCI 10.0010X**
- Compliance with the Essential Health and Safety Requirements has been assured by compliance with the International and European Standards IEC and EN: 60079-0, 60079-1 and 60079-31
- Easy electrical installation by means of a screw terminal coil
- Enclosure provided with a 1/2 NPT threaded entry hole for a broad range of cable entries
- Ingress protection degree IP67 - NEMA 4/4X
- A wide range of valves can be supplied with the operator

CONSTRUCTION

Solenoid enclosure	LPKF WSLPKF	Aluminium, cataphoresis black painting Stainless steel (AISI 316L)
Bonnet	LPKF WSLPKF	Stainless steel Stainless steel (AISI 316L)
Cover screws		Stainless steel
Core, core tube and plugnut		Stainless steel
Seals		VMQ
Upper disc		FPM
Lower disc		NBR
Nameplate		Stainless steel
Coil connection		Embedded screw terminals
Safety code		II2G Ex d IIB+H2 Gb T6...T4 II2D Ex tb IIIC Db T85°C...T135°C IP66/IP67

ELECTRICAL CHARACTERISTICS

Standard voltages	DC (=) : 24V - 48V AC (~) : 24V - 48V - 115V - 230V / 50 Hz
--------------------------	--

TEMPERATURE CLASSIFICATION TABLES

AC solenoids (-)							DC solenoids (=)						
Pn (watt)	solenoid size			maximum ambient °C ^{(1) (5)}			Pn (watt)	solenoid size			maximum ambient °C ^{(1) (5)}		
	surface temperature			T6	T5	T4		surface temperature			T6	T5	T4
		M6		85°C	100°C	135°C			M6		85°C	100°C	135°C
insulation class F (155°C) 100% E.D.							insulation class F (155°C) 100% E.D.						
-				-	-	-	0,5 ⁽³⁾		●		60	-	-
2,4 ^{(2) (4)}		●		40	65	80	2,1 ⁽⁴⁾		●		40	-	80

Check the wattage compatibility with the product selected.

⁽¹⁾ The minimum allowable ambient temperature is -40°C for the operator. Actual temperature range can be limited depending on valve operation limits.

⁽²⁾ AC (-): rectified coil construction.

⁽³⁾ 24 V DC value.

⁽⁴⁾ Maximum cold wattage.

⁽⁵⁾ For the layout of the control circuit, see the installation and maintenance instructions at: www.asco.com

CONNECTIONS

- Any IECEx-ATEX approved cable entry device can be fitted in the 1/2" NPT threaded entry hole
- Internal and external earthing connection
- The operator can be rotated through 360° to select the most favourable position for cable entry

OPTIONS

- Brass nickel plated cable gland

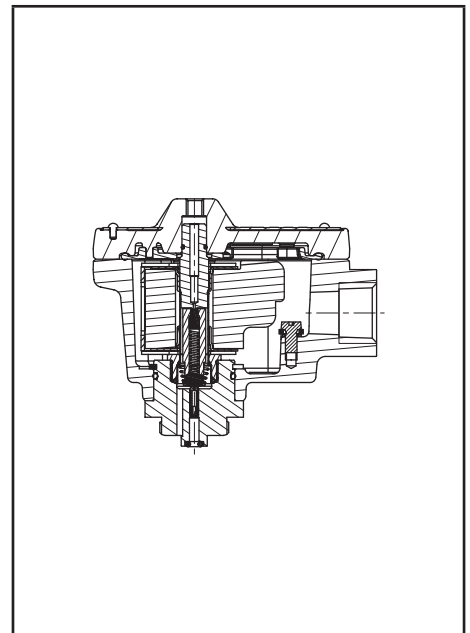

ORDERING INFORMATION

A valve supplied with the explosionproof operator will be identified with prefix LPKF or WSLPKF before the catalogue number.

Example: **LPKF** G 551B305 24V/DC

LPKF G 552A301 230V/AC

WSLPKF G 553A318 230V/AC

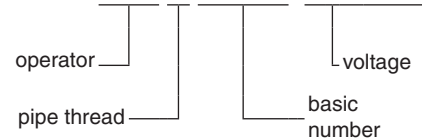

DIMENSIONS (mm), WEIGHT (kg) 



TYPE LPKF

Prefix "LPKF" Solenoid
Aluminium, epoxy coated
IEC, EN: 60079-1, 60079-31
II2G Ex d IIB+H2 Gb T6...T4 - II2D Ex tb IIIC Db IP66/IP67

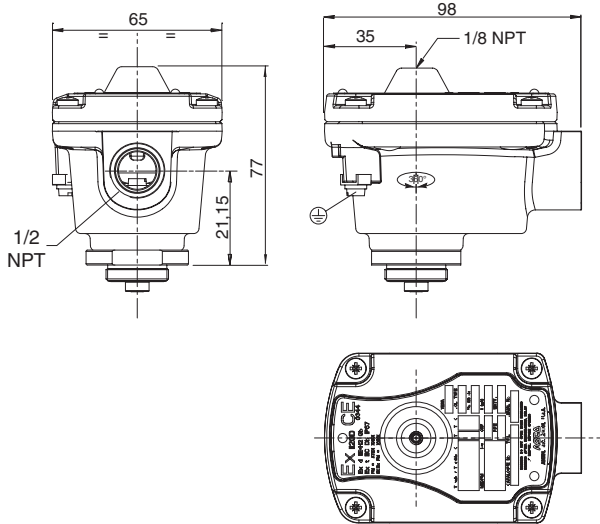

TYPE WSLPKF

Prefix "WSLPKF" Solenoid
Stainless steel, epoxy coated
IEC, EN: 60079-1, 60079-31
II2G Ex d IIB+H2 Gb T6...T4 - II2D Ex tb IIIC Db IP66/IP67

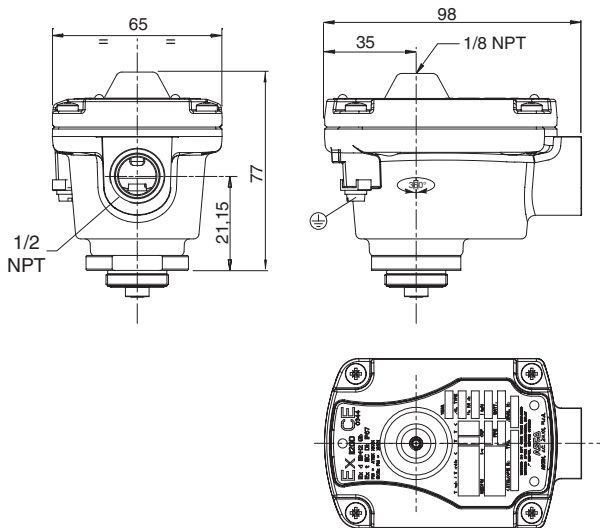

prefix	weight
LPKF	0,55
WSLPKF	1,16

All leaflets are available on: www.asco.com

2 - Explosionproof equipment



青岛秉诚自动化设备有限公司
地址：中国·青岛市重庆南路99号海尔云街甲3号楼7F

服务热线：4006-918-365
网址：<http://www.asco.store>

传真：(86-532)585-10-365
Email：sales@bechinas.com



OPERATORS

for potentially explosive atmospheres
flameproof enclosure
II 2G/D Ex db IIC T6..T4 Gb / Ex tb IIIC Db IP66/IP67
aluminium or stainless steel enclosure



Series
NF
WSNF

FEATURES

- Explosionproof operator for use in potentially explosive atmospheres according to ATEX-Directive 2014/34/EU
EC type examination certificate no.: **LCIE 00 ATEX 6008 X**
IECEX Certificate of Conformity no.: **IECEX LCI 07.0015X**
- Compliance with the Essential Health and Safety Requirements has been assured by compliance with the International and European Standards EN-IEC 60079-0, EN-IEC 60079-1 and EN-IEC 60079-31
- Easy electrical installation by means of a screw terminal coil
- Enclosure provided with a 1/2 NPT threaded entry hole (M20 x 1,5 in option) for a broad range of cable entries
- Ingress protection degree IP66/67
- A wide range of valves can be supplied with the operator

CONSTRUCTION

Solenoid enclosure

NF Chromated aluminium, epoxy coated
WSNF Stainless steel (AISI 316L)

Bonnet

NF Steel (zinc plated)
WSNF Stainless steel (nickel plated)

Core, core tube and plugnut

all Stainless steel

Shading coil

all Copper or silver

Nameplate

NF Stainless steel

WSNF Stainless steel

Coil connection

all Embedded screw terminals

Fasteners & screws

all Stainless steel

Safety code

IECEX / II 2G Ex db IIC T6..T4 Gb
IECEX / II 2D Ex tb IIIC 85°C..135°C Db IP66/67

ELECTRICAL CHARACTERISTICS

Standard voltages

(Other voltages and 60 Hz on request)

DC (=) : 24V - 48V

AC (~) : 24V - 48V - 115V - 230V⁽³⁾ / 50 Hz

TEMPERATURE CLASSIFICATION TABLES

AC (~) solenoids

Pn (watt)	solenoid size		maximum ambient °C ⁽¹⁾			
	MX	M12	surface temperature			
			T6 85°C	T5 100°C	T4 135°C	T3 200°C
insulation class F/H (155°C/180°C) 100% E.D.						
1,85 ⁽²⁾⁽³⁾	●		75	80		
3,7 ⁽²⁾	●		60	75	100	
5,8 ⁽²⁾	●		60	75	100	
10,0 ⁽²⁾	●		40	60	75	
10,0 ⁽²⁾	●		40	60	100	
10,5	●		25	40	60	
13,4 ⁽²⁾	●		40	60	75	
14,1 ⁽²⁾	●		40	60	90	
15,4	●		25	40	60	
16,5	●		40	60	75	
16,7	●			25	40	
20,0	●			25	40	
20,5	●				25	
28,0	●				25	

DC (=) solenoids

Pn (watt)	solenoid size		maximum ambient °C ⁽¹⁾			
	MX	M12	surface temperature			
			T6 85°C	T5 100°C	T4 135°C	T3 200°C
insulation class F/H (155°C/180°C) 100% E.D.						
1,8	●		75	80		
3,6	●		60	75	100	
5,7	●		60	75	100	
10,0	●		40	60	100	
11,2	●		40	60	75	
14,0	●		40	60	90	
16,8	●		40	60	75	
19,7	●		25	40	60	
23,0	●		25	40	60	
26,6	●		25	40	60	
29,5	●			25	40	
36,2	●			25	40	

Check the wattage compatibility with the product selected.

⁽¹⁾ The minimum allowable ambient temperature is -60°C for the operator. Actual temperature range can be limited depending on valve operation limits.

⁽²⁾ AC (~): rectified coil construction.

⁽³⁾ 230 V AC does not exist (Pn 1,85 W).

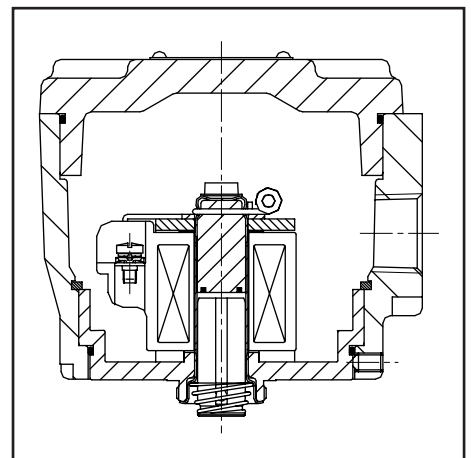

ORDERING INFORMATION

A valve supplied with the explosionproof operator will be identified with prefix NF or WSNF before the catalogue number.

Example: **NF E 210D095 230V/50 Hz**

operator — voltage
pipe thread ISO 7/1 — basic number

A valve supplied with the explosionproof operator will be identified with electrical interface FN, FS, FT or FU in the 15-digit product code.

15-DIGIT PRODUCT CODE

E 262 K 232 FN V00 H1

Thread connection — Voltage-class
Product series — Options
Revision letter —
Valves version —
Electrical interface

FN = NF

FS = WSNF

FT = NFET

FU = WSNFET

00130GB-2018/R01
Availability, design and specifications are subject to change without notice. All rights reserved.

All leaflets are available on: www.asco.com



青岛秉诚自动化设备有限公司
地址：中国·青岛市重庆南路99号海尔云街甲3号楼7F

服务热线：4006-918-365
网址：http://www.asco.store

Explosionproof equipment - 3
传真：(86-532)585-10-365
Email：sales@bechinas.com

OPTIONS

• Operators for mining, I M2 Ex d I, contact us

ORDERING EXAMPLES:

NF	B	327	B	001	230V / 50 Hz
NF	G	551	B	405	230V / 50 Hz
NFET	G	327	B	001 V	230V / 50 Hz
WSNF	E	272	A	047 MS	24V / DC
WSNF	B	320	A	184 E	24V / DC

prefix ———
 pipe thread ———
 basic number ———
 voltage ———
 suffix ———

MOUNTING BRACKET

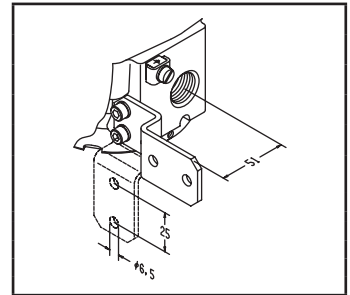

Bracket kit no. **C139824**
contains: Stainless steel 304 SS screws and bracket

15-DIGIT PRODUCT CODE

E	262	K	232	FN	V00	H1
E	262	K	232	FS	V00	F8
E	262	K	232	FT	V00	FT
E	262	K	232	FU	V00	H9

Thread connection ———
 Product series ———
 Revision letter ———
 Valves version ———
 Electrical interface ———
 Voltage - class ———
 Options ———

CONNECTIONS

- Any ATEX approved cable entry device can be fitted in the 1/2 NPT threaded entry hole (M20 x 1.5 in option). Refer to the nameplate for identification of the maximum cable temperature
- Internal and external earthing connection
- The operator can be rotated through 360° to select the most favourable position for cable entry

DIMENSIONS (mm), WEIGHT (kg)



TYPE NF-WSNF
Prefix "NF", "WSNF" Solenoid / Electrical interface FN/FS/FT/FU
Aluminium, stainless steel
(NF, epoxy coated)
EN-IEC 60079-1 and EN-IEC 60079-31
II 2G Ex db IIC Gb, II 2D Ex tb IIIC Db IP66/67

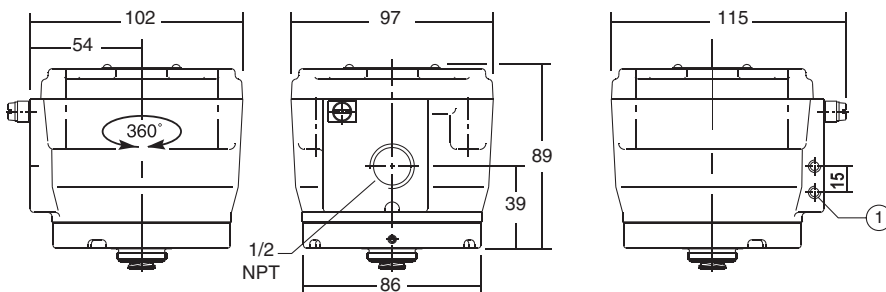

series	weight
NF	1,4
WSNF	2,7

① 2 mounting holes M5, depth 9 mm

FEATURES

- Explosionproof operator for use in potentially explosive atmospheres according to ATEX-Directive 2014/34/EU
EC type examination certificate no.: **LCIE 10 ATEX 3043X**
IECEX Certificate of Conformity no.: **IECEX LCI 10.0010X**
- Compliance with the Essential Health and Safety Requirements has been assured by compliance with the International and European Standards IEC and EN: 60079-0, 60079-1 and 60079-31
- Easy electrical installation by means of a screw terminal coil
- Enclosure provided with a 1/2 NPT threaded entry hole for a broad range of cable entries
- A wide range of valves can be supplied with the CNOMO size 30 solenoid pilot interface

GENERAL

Differential pressure	See «SPECIFICATIONS» [1 bar =100 kPa]
Flow	See «SPECIFICATIONS»
Pneumatic base	ISO 15218 (CNOMO E06.05.80, size 50)
Response time	70 - 140 ms

fluids (*)	temperature range (TS)	seal materials (*)
air or inert gas	- 25°C to +60°C	NBR (nitrile) FPM (fluoroelastomer) VMQ (silicone)

GENERAL

Solenoid enclosure	Aluminium, cataphoresis black painting
Cover screws	Stainless steel
Nameplate	Aluminium

MATERIALS IN CONTACT WITH FLUID	
(*) Ensure that the compatibility of the fluids in contact with the materials is verified	
Body	Aluminium, black painting
Core, core tube and plugnut	Stainless steel
Springs	Stainless steel
Seals	VMQ
Upper disc	FPM
Lower disc	NBR

SAFETY CODE

Gas	II2G Ex d IIB+H2 Gb T6..T4
Dust	II2D Ex tb IIIC Db T85°C...T135°C IP66/IP67

ELECTRICAL CHARACTERISTICS

Coil insulation class	F
Coil connection	Embedded screw terminals
Electrical enclosure protection	IP67 (EN 60529)
Standard voltages	DC (=) : 24V - 48V
(Other voltages on request)	AC (~) : 24V - 48V - 115V - 230V/50-60 Hz

TEMPERATURE CLASSIFICATION TABLES

AC solenoids (~)					
Un (V)	Pn (watt) (2)(3)	solenoid size M6	maximum ambient °C (1) (4)		
			surface temperature		
			T6 85°C	T5 100°C	T4 135°C
24	5,4	●	40	-	60
48	5,8	●	40	-	60
115	7,1	●	-	40	60
230	7,4	●	-	40	60

DC solenoids (=)					
Un (V)	Pn (watt)	solenoid size M6	maximum ambient °C (1) (4)		
			surface temperature		
			T6 85°C	T5 100°C	T4 135°C
24	5,9	7,5 (3)	●	-	40
48	6	7,6 (3)	●	-	40

(1) The minimum allowable ambient temperature is -25°C for the operator. Actual temperature range can be limited depending on valve operation limits.

(2) Rectified coil construction.

(3) Maximum cold wattage.

(4) For the layout of the control circuit, see the installation and maintenance instructions at: www.asco.com

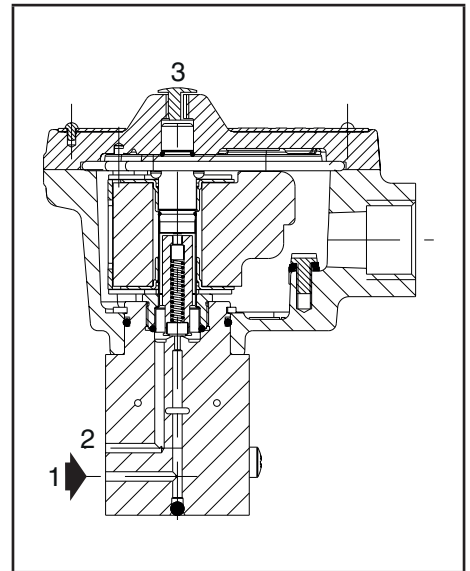

SPECIFICATIONS

pipe size	orifice size (mm)	flow coefficient Kv				operating pressure differential (bar)				thread type	dimensions / type (1)	15-DIGIT PRODUCT CODE						
		1 → 2		2 → 3		min.	max. (PS)					brass	voltage code					
		(m³/h)	(l/min)	(m³/h)	(l/min)		air, inert gas (*)						24 V/50 Hz	48 V/50 Hz	115 V/50 Hz	230 V/50 Hz	24 V/DC	48 V/DC
		~	=															
WITHOUT MANUAL OPERATOR																		
NC - Normally closed, NBR seal and disc																		
1/4	1,6	0,08	1,3	0,05	0,8	0	10	10	pad mount	01	R314K311GNN00	FQ	FS	FC	FH	F1	F9	
WITH MAINTAINED MANUAL OPERATOR																		
NC - Normally closed, NBR seal and disc																		
1/4	1,6	0,08	1,3	0,05	0,8	0	10	10	pad mount	01	R314K311GNN01	FQ	FS	FC	FH	F1	F9	

(1) For dimensions, see drawing(s) for each construction type on the following page(s).

(*) Ensure that the compatibility of the fluids in contact with the materials is verified.

15-DIGIT PRODUCT CODE

R
314
K
311
GN
N00
F1

Connection
R = Pad mount

Product series
314

Revision letter
K = Initial release

Valves version
311 = ISO 15218 (CNOMO E06.05.80, size 30)
1,6 mm orifice size / LPKF

Voltage - class
FQ = 24 V / 50-60 Hz - class F
FS = 48 V / 50-60 Hz - class F
FC = 115 V / 50-60 Hz - class F
FH = 230 V / 50-60 Hz - class F
F1 = 24 V DC - class F
F9 = 48 V DC - class F

Options
Without manual operator
N00 = NBR disc and seals

With maintained manual operator
N01 = NBR disc and seals

Electrical interface
Standard
GN = 1/2 NPT female thread cable entry screw terminal

Option
GT = M20 x 1,5 female thread cable entry screw terminal

INSTALLATION

- The solenoid valves can be mounted in any position without affecting operation
- The solenoid valves are supplied with mounting screws
- Mounting on valve or single, non-joinable subbase with ISO 15218 (CNOMO, size 30) interface
- Installation/maintenance instructions are included with each valve

OPERATOR CONNECTION

- Any ATEX approved cable entry device can be fitted in the 1/2" NPT threaded entry hole (M20 x 1.5, in option); supplied without cable gland
- Internal and external earthing connection
- The operator can be rotated through 360° to select the most favourable position for cable entry

DIMENSIONS (mm), WEIGHT (kg)

TYPE 01
Electrical interface "GN"
IEC, EN: 60079-1, 61241-1
II2G Ex d IIB+H2 Gb T6..T4
II2D Ex tb IIIC Db IP66/IP67 T85°C..T135°C

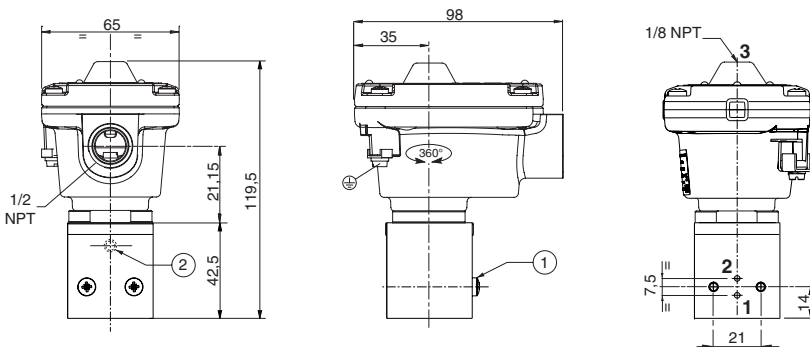

type	weight (2)
01	0,7

- ① Mounting: two screws M4 x 35
② Manual operator location

(2) Without cable gland.

All leaflets are available on: www.asco.com

FEATURES

- Explosionproof operator for use in potentially explosive atmospheres according to ATEX-Directive 2014/34/EU
EC type examination certificate no.: **BAS 98 ATEX 2168 X**
IECEX Certificate of Conformity no.: **IECEX SIR 06.109X**
- Compliance with the Essential Health and Safety Requirements has been assured by compliance with the International and European Standards EN-IEC 60079-0 and EN-IEC 60079-18
- Easy electrical installation with moulded-in supply cable, 2 m long
- Ingress protection degree IP67
- The operators are designed for installation on a wide range of valves

CONSTRUCTION

Solenoid enclosure

Core tube

Plugnut

Shading coil

Nameplate

Safety code

Epoxy encapsulated

Stainless steel

Stainless steel

Copper or silver

Polyester

IECEX / II 2G Ex mb IIC T5..T3 Gb

IECEX / II 2D Ex mb IIC 100°C..200°C Db IP67

ELECTRICAL CHARACTERISTICS

Standard voltages

(Other voltages and 60 Hz on request)

DC (=) : 24V - 48V

AC (~) : 24V - 48V - 115V - 230V / 50 Hz

TEMPERATURE CLASSIFICATION TABLES

AC solenoids (~)

Pn (watt)	solenoid size		maximum ambient °C ⁽¹⁾			
	EM5	EMXX	surface temperature			
			T6 85°C	T5 100°C	T4 135°C	T3 200°C
insulation class F (155°C) 100% E.D.						
2,5	●		-	-	60	65
4,0 ⁽²⁾	●		-	-	60	65
4,05		●	-	-	-	65
6,3 ⁽³⁾	●		-	-	-	65
10,5		●	-	-	-	65
insulation class F (155°C) 10% E.D.						
10,0	●		-	-	-	65

DC solenoids (=)

Pn (watt)	solenoid size		maximum ambient °C ⁽¹⁾			
	EM5	EMXX	surface temperature			
			T6 85°C	T5 100°C	T4 135°C	T3 200°C
insulation class F (155°C) 100% E.D.						
1,7		●	65	-	-	-
3,0 ⁽⁴⁾	●		-	40	60	60
6,9 ⁽⁵⁾	●		-	-	-	40
11,2		●	-	-	65	70
19,7	●		-	-	40	70
insulation class F (155°C) 10% E.D.						
15,0	●		-	-	-	40
22,0	●		-	-	-	40

Check the wattage compatibility with the product selected.

⁽¹⁾ **Allowable minimum ambient temperature: -40°C.** Actual temperature range may be limited depending on valve operation limits.

⁽²⁾ AC series 189 - 189 banjo - 256/356 (1/8-1/4) - 551 integrated pilot - 238 (3/8 to 1)

⁽³⁾ AC series 552/553

⁽⁴⁾ DC series 189 - 189 banjo - 551 integrated pilot

⁽⁵⁾ DC series 552 - 553 - 256/356 1/8-1/4 - 238 (3/8 to 1)

CONNECTIONS

- The solenoid can be rotated through 360° to select the most favourable position for the cable.

ORDERING INFORMATION ON EXCEPTIONS

- **PV + 18901...** , for series: 189 - 189 banjo

Example: **PV** 18901001 230V/50 Hz
PV 18901010 24V/DC
PV 18901032 230V/50 Hz
PV 18901047 24V/DC

- **PV + TPL number 20787** , for series: 551 integrated pilot - 238 (floating diaphragm, 3/8 to 1, catalogue nos. including the letterD...) - 256/356 1/8

Example: **PVX** G551A005 24V/DC **20787**
PVX G551A006 48V/DC **20787**
PVX G551A017 24V/50 Hz **20787**
PVX G551A018 48V/50 Hz **20787**
PVX G551A001 115V/50 Hz **20787**
PVX E238D001 230V/50 Hz **20787**
PVX E238D008 24V/DC **20787**
PVX G256A002VMS 24V/DC **20787**
PVX G356A002VMS 230V/50 Hz **20787**

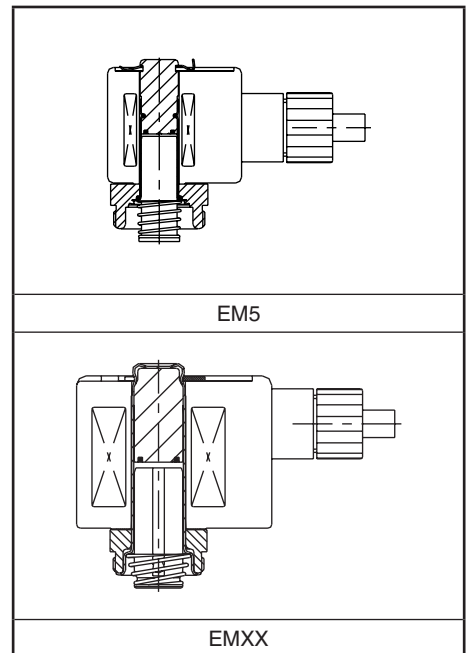

ORDERING INFORMATION

(See Ordering Information on Exceptions)

A valve with the explosionproof operator will be identified with the prefix PV before the catalogue number.

Example: **PV E 210D095 230V/50 Hz**

solenoid operator | voltage
pipe thread | basic number

A valve supplied with the explosionproof operator will be identified with electrical interface A7 in the 15-digit product code.

15-DIGIT PRODUCT CODE

E 262 K 232 A7 V00 H1

Thread connection | Product series | Valves version | Electrical interface | Options
Voltage-class

A7 = PV

All leaflets are available on: www.asco.com

ORDERING EXAMPLES:

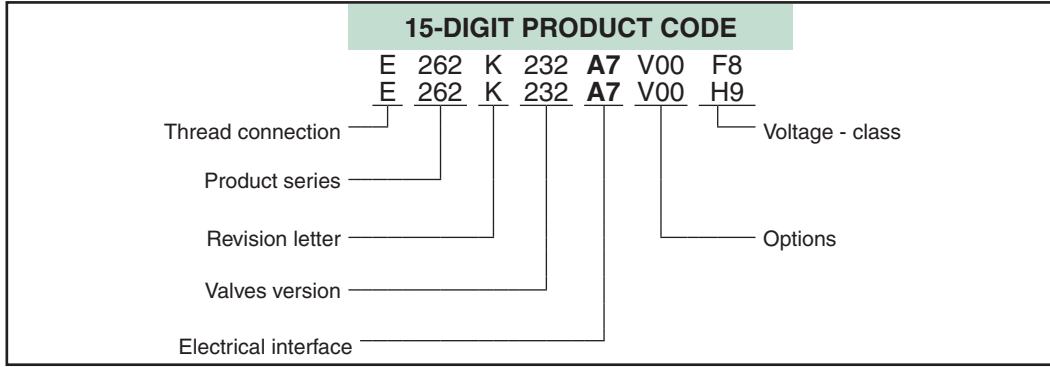

DIMENSIONS (mm), WEIGHT

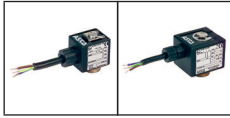

TYPE PV

Prefix "PV" solenoids / Electrical interface A7
 Epoxy coated
 EN-IEC 60079-18
 II 2G Ex mb IIC Gb - II 2D Ex mb IIIC Db IP67

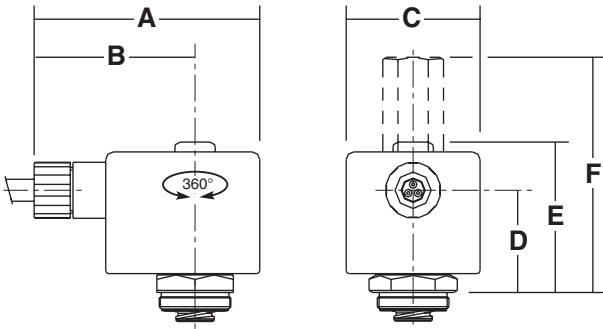

size	A	B	C	D	E	F	weight ⁽¹⁾
EM5	60	45	29	21	38,5	66	0,113
EMXX	75	53,5	44,5	33,6	49,4	77,3	0,348

FEATURES

- Explosionproof operator for use in potentially explosive atmospheres according to ATEX-Directive 2014/34/EU
EC type examination certificate no.: **LCIE 12 ATEX 3005 X**
IECEX Certificate of Conformity no.: **IECEX LCI 12.0002X**
- Compliance with the Essential Health and Safety Requirements has been assured by compliance with the International and European Standards EN-IEC 60079-0, EN-IEC 60079-7, EN-IEC 60079-18 and EN-IEC 60079-31
- Easy electrical installation by means of a screw terminal coil
- Peak voltage suppression standard for DC executions
- The coil winding is fitted with a thermal fuse (in AC/DC) which will trip in case of excessive temperature due to prolonged overvoltage or a blocked core and cause the valve to de-energise and fail-safe
- Enclosure provided with integral strain relief for cable with an O.D. of 7 to 8,5 mm
- Ingress protection degree IP67
- A wide range of valves can be supplied with the operator



CONSTRUCTION

Solenoid enclosure
Cable gland
Nameplate
Coil connection
Safety code



PBT
PA 66, M20 x 1,5
Polyester
Embedded screw terminals
II 2G Ex e mb IIC T4 Gb
II 2D Ex tb IIIC T 135°C Db IP67

ELECTRICAL CHARACTERISTICS

Standard voltages

DC (=) : 24V - 48V
AC (~) : 24V - 48V - 115V - 230V / 50 Hz

TEMPERATURE CLASSIFICATION TABLES

AC (~) solenoids

Pn (watt)	solenoid size				maximum ambient °C ⁽¹⁾	
	WBLP				surface temperature	
					T4	135°C
insulation class F (155°C) 100% E.D.						
3,5 ⁽²⁾	●				65	

DC (=) solenoids

Pn (watt)	solenoid size				maximum ambient °C ⁽¹⁾	
	WBLP				surface temperature	
					T4	135°C
insulation class F (155°C) 100% E.D.						
4	●				65	

Check the wattage compatibility with the product selected.

⁽¹⁾ The minimum allowable ambient temperature is -40°C for the operator. Actual temperature range can be limited depending on valve operation limits.

CONNECTIONS

- Internal and external earthing connection
- The operator can be rotated through 360° to select the most favourable position for cable entry

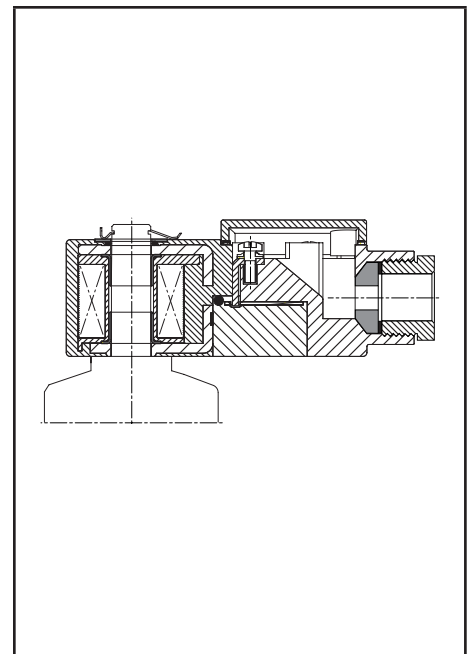

ORDERING INFORMATION

A valve supplied with the explosionproof operator will be identified with prefix WBLP before the catalogue number.

Example:

WBLP G 551A005 230V/50 Hz
WBLP G 553A005 230V/50 Hz

operator — voltage
pipe thread — basic number

DIMENSIONS (mm), WEIGHT (kg)



TYPE WBLP

Prefix "WBLP" solenoids
 EN-IEC 60079-7, EN-IEC 60079-18 and EN-IEC 60079-31
 II 2G Ex e mb IIC T4 Gb, II 2D Ex tb IIIC T135°C Db IP67

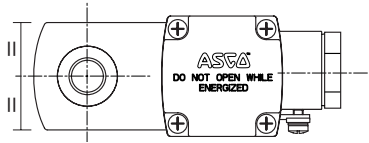
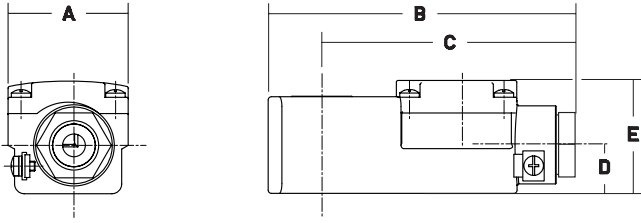

prefix	A	B	C	D	E	weight
WBLP	37	98	81,5	15	35,2	0,18



ACCESSORIES

Supply rail with pressure isolation valves
 Aluminium
 Inlet G 1/2, outlets G 1/4



supply rail for «n» valves with end pieces and low 65 mm mounting brackets

number of outlets	4	6	8	10	12	15
catalogue number	88100970	88100971	⁽¹⁾	⁽¹⁾	⁽¹⁾	⁽¹⁾
L (mm)	177	259	341	423	505	628

⁽¹⁾ Contact us.

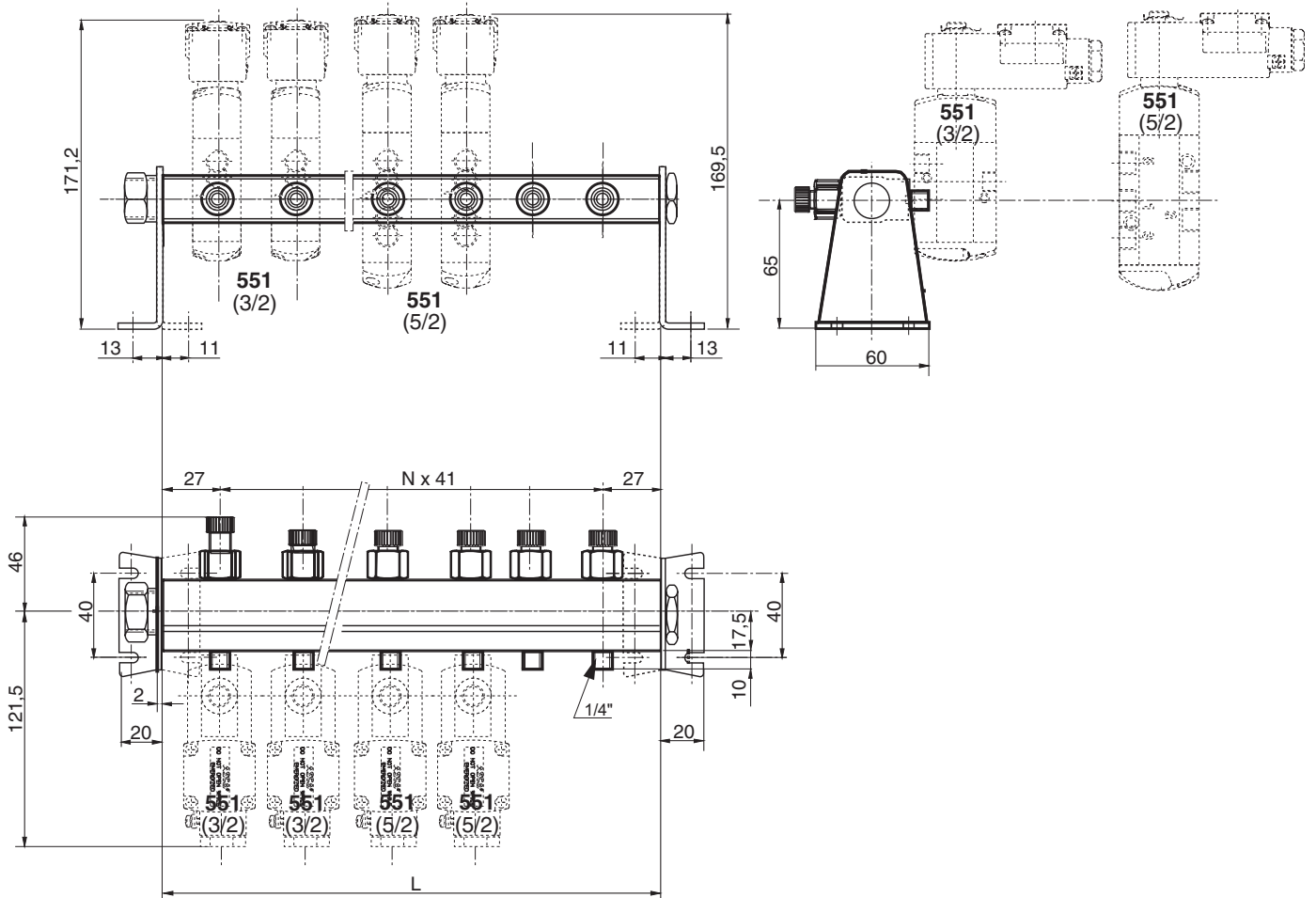

All leaflets are available on: www.asco.com



OPERATORS

for potentially explosive atmospheres
increased safety/encapsulation
II 2 G Ex e mb II T6..T3 Gb, II 2 D Ex tb IIIC T85°C..
T200°C Db IP66/67, steel or stainless steel enclosure



Series
EM
WSEM

FEATURES

- Explosionproof operator for use in potentially explosive atmospheres according to ATEX-Directive 2014/34/EU
EC type examination certificate no.: **KEMA 98 ATEX 2542 X**
IECEX Certificate of Conformity no.: **IECEX KEM 08.0002X**
- Compliance with the Essential Health and Safety Requirements has been assured by compliance with the International and European Standards EN-IEC 60079-0, EN-IEC 60079-7, EN-IEC 60079-18 and EN-IEC 60079-31
- Easy electrical installation by means of a screw terminal coil
- Peak voltage suppression standard for DC executions
- Enclosure provided with integral strain relief for cable with an o.d. of 7 to 12 mm
- Ingress protection degree IP66/67
- A wide range of valves can be supplied with the operator

CONSTRUCTION

Solenoid enclosure

EM Zinc plated steel (epoxy coated)
WSEM Stainless steel, AISI 316

Cable gland

PA, M20 x 1,5

Core, core tube and plugnut

Stainless steel

Shading coil

Copper or silver

Nameplate

Polyester

Coil connection

Embedded screw terminals

Safety code

II 2G Ex e mb IIC T6..T3 Gb
II 2D Ex tb IIIC 85°C..200°C Db IP66/67



ELECTRICAL CHARACTERISTICS

Standard voltages

(Other voltages and 60 Hz on request)

DC (=) : 24V - 48V

AC (~) : 24V - 48V - 115V - 230V / 50 Hz

TEMPERATURE CLASSIFICATION TABLES

AC (~) solenoids

Pn (watt)	solenoid size			maximum ambient °C ⁽¹⁾			
	M6	MXX	M12	surface temperature			
				T6 85°C	T5 100°C	T4 135°C	T3 200°C
insulation class F (155°C) 100% E.D.							
1,2 ⁽²⁾		•		60	75		
1,5 ⁽²⁾	•			40	55		
1,85 ⁽²⁾		•		40	55		
3,7 ⁽²⁾		•		40	55	75	
5,8 ⁽²⁾		•			40	75	-
6,0	•						40
9,0	•						40
10,0 ⁽²⁾		•					40
10,0 ⁽²⁾			•			40	65
10,5		•					40
13,0		•					40
13,6 ⁽²⁾		•					40
14,1 ⁽²⁾		•					40
16,5		•					40

DC (=) solenoids

Pn (watt)	solenoid size			maximum ambient °C ⁽¹⁾			
	M6	MXX	M12	surface temperature			
				T6 85°C	T5 100°C	T4 135°C	T3 200°C
insulation class F (155°C) 100% E.D.							
1,3		•		60	75		
1,7		•		40	55		
1,8		•		40	55		
3,6		•		40	55	75	
5,7		•			40	75	-
9,7	•						40
10,0		•					40
11,2		•					40
14,0		•					40
15,3	•						40
16,8		•					40
19,7		•					40

Check the wattage compatibility with the product selected.

⁽¹⁾ The minimum allowable ambient temperature is -40°C for the operator. Actual temperature range can be limited depending on valve operation limits.

⁽²⁾ AC (-): rectified coil construction.

CONNECTIONS

- Internal and external earthing connection
- The operator can be rotated through 360° to select the most favourable position for cable entry

OPTIONS

- Brass nickel plated or stainless steel cable gland
- Conduit hub, 1/2 NPT, M20 x 1,5, 3/4 NPT or M25 x 1,5 in aluminium or stainless steel
- Special moulded-in solid state components for peak voltage suppression and/or rectification (four-diode bridge)



EM



WSEM

ORDERING INFORMATION

A valve supplied with the explosionproof operator will be identified with prefix EM or WSEM before the catalogue number.

Example: **WSEM E 210D095 230V/50 Hz**

EM E 210D095 230V/50 Hz



A valve supplied with the explosionproof operator will be identified with electrical interface MV, MW, MT, MS, MN or MU in the 15-digit product code.

15-DIGIT PRODUCT CODE

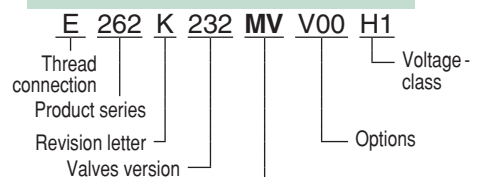

Electrical interface

MV = EM
MW = WSEM
MT = EMET
MS = WSEMT
MN = EMT
MU = WSEMET

All leaflets are available on: www.asco.com

00135GB-2017/R01
Availability, design and specifications are subject to change without notice. All rights reserved.



青岛秉诚自动化设备有限公司
地址：中国·青岛市重庆南路99号海尔云街甲3号楼7F

服务热线：4006-918-365
网址：http://www.asco.store

Explosionproof equipment - 11
传真：(86-532)585-10-365
Email：sales@bechinas.com

ORDERING EXAMPLES:

15-DIGIT PRODUCT CODE						
E	262	K	232	MV	V00	H1
E	262	K	232	MW	V00	F8
E	262	K	232	MT	V00	FT
E	262	K	232	MS	V00	FT
E	262	K	232	MN	V00	FT
E	262	K	232	MU	V00	H9

Thread connection ————
 Product series ————
 Revision letter ————
 Valves version ————
 Electrical interface ————

Voltage - class ————
 Options ————

DIMENSIONS (mm), WEIGHT (kg)



TYPE EM/WSEM

Prefix "EM"/"WSEM" solenoids / Electrical interface MV/MW/MT/MS/MN/MU
 Pull-type solenoid operator
 Metal enclosure, epoxy coated or stainless steel
 EN-IEC 60079-7, EN-IEC 60079-18 and EN-IEC 60079-31
 II 2G Ex e mb IIC Gb, II 2D Ex tb IIIC Db IP66/67

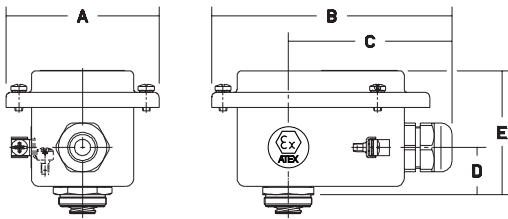

series/size	A	B	C	D	E	weight
EM/WSEM-M6	77	120	82	26	64	0,48
EM/WSEM-MXX	77	120	82	23	62	0,55
EM/WSEM-M12	77	120	82	21	65	0,67

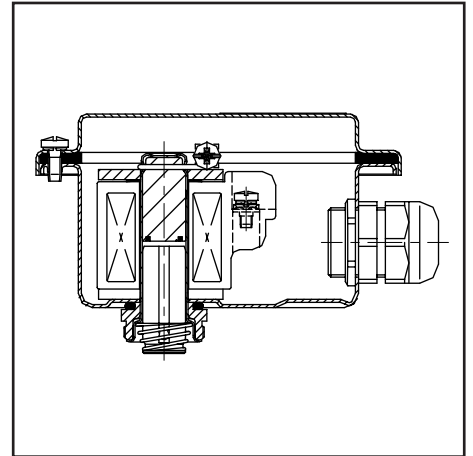

TYPE EM/WSEM

Prefix "EM"/"WSEM" solenoids / Electrical interface MV/MW/MT/MS/MN/MU
 Push-type solenoid operator
 Metal enclosure, epoxy coated or stainless steel
 EN-IEC 60079-7, EN-IEC 60079-18 and EN-IEC 60079-31
 II 2G Ex e mb IIC Gb, II 2D Ex tb IIIC Db IP66/67

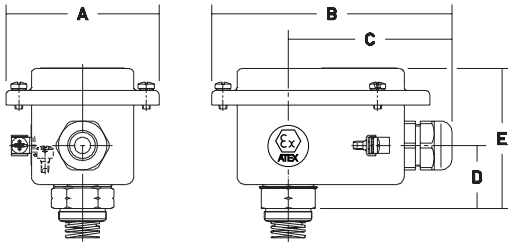

series/size	A	B	C	D	E	weight
EM/WSEM-M6	77	120	82	25	63	0,50
EM/WSEM-MXX	77	120	82	31	69	0,59
EM/WSEM-M12	77	120	82	30	73	0,70

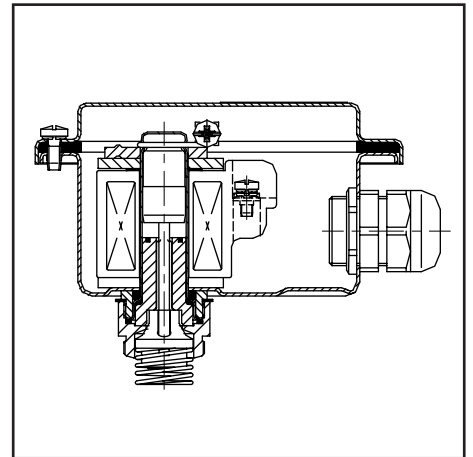

TYPE EM/WSEM

Prefix "EM"/"WSEM" solenoids / Electrical interface MV/MW/MT/MS/MN/MU
 Pull-type solenoid operator
 Metal enclosure, epoxy coated or stainless steel
 EN-IEC 60079-7, EN-IEC 60079-18 and EN-IEC 60079-31
 II 2G Ex e mb IIC Gb, II 2D Ex tb IIIC Db IP66/67

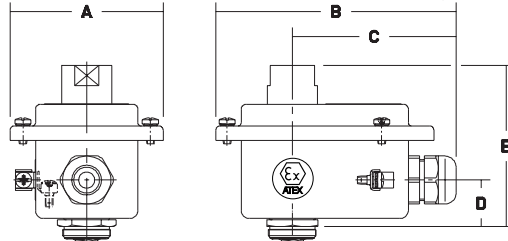

series/size	A	B	C	D	E	weight
EM/WSEM-MXX	77	120	82	23	80	0,68

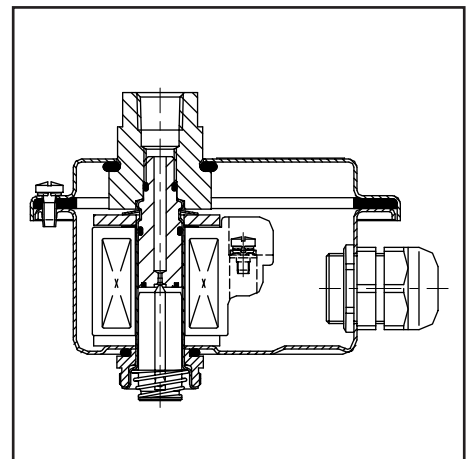

All leaflets are available on: www.asco.com

FEATURES

- Explosionproof operator for use in potentially explosive atmospheres according to ATEX-Directive 2014/34/EU
EC type examination certificate no.: **LCIE 09 ATEX 3054 X**
IECEX Certificate of Conformity no.: **IECEX LCI 09.0022X**
- Compliance with the Essential Health and Safety Requirements has been assured by compliance with the International and European Standards IEC and EN: 60079-0, 60079-11 and 60079-31
- Easy electrical installation by means of a screw terminal coil
- Enclosure provided with a cable gland for unarmoured cable with an o.d. of 6 to 12 mm
- Ingress protection degree IP67
- For solenoid operator type WSLI for use in mines susceptible to firedamp, group I: see "Options"
- A wide range of valves can be supplied with the operator

CONSTRUCTION

Solenoid enclosure	LI	Aluminium, cataphoresis black painting
	WSLI	Stainless steel (AISI 316L)
Bonnet	LI	Stainless steel
	WSLI	Stainless steel (AISI 316L)
Cover screws		Stainless steel
Core, core tube and plugnut		Stainless steel
Seals		VMQ
Upper disc		FPM
Lower disc		NBR
Nameplate		Stainless steel
Coil connection		Embedded screw terminals
Cable gland		Polyamide (PA), 1/2 NPT (cable Ø 7-12 mm)
Safety code	LI ⁽¹⁾ / WSLI ⁽¹⁾	II 1G Ex ia IIC T6 Ga II 2D Ex tb IIIC T85°C IP66/IP67 Db

⁽¹⁾ For use in zone 0 locations, see the installation conditions given in the I&M instructions.

ELECTRICAL CHARACTERISTICS

Coil insulation class **F**
Standard voltages **DC (=) : 24V**

voltage (U _n) (max. ripple 10%)	power ratings (P _n) hot/cold =	typical functional ratings		R		operator ambient temperature range (TS) (°C) ⁽²⁾	type ⁽⁴⁾
		I _{(ON) min.}	U _{(ON) min.}	20°C	max. T6		
(V)	(W)	(mA)	(V)	(Ω)	(Ω)		
24	0,5	32	12,5	288	354	-40 to +60	01

P _n	safety parameters					safe area (RS interface)	explosive area
	U _i = (DC)	I _i	P _i	L _i	C _i		
(W)	(V)	(mA)	(W)	(H)	(μF)		
0,5	32	500	1,5	0	0		

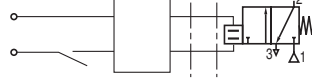

Example of use with a Zener barrier installed in a non-hazardous zone

TEMPERATURE CLASSIFICATION TABLES

DC (=) solenoids

P _n (watt)	solenoid size		maximum ambient °C ⁽²⁾
		M6	surface temperature
			T6 85°C
insulation class F (155°C) 100% E.D. ⁽³⁾			
0,5		●	60

Check the wattage compatibility with the product selected.

⁽²⁾ The minimum allowable ambient temperature is **-40°C for the operator**. Actual temperature range can be limited depending on valve operation limits. **-35°C max. with polyamide cable gland.**

⁽³⁾ This intrinsically safe valve must be connected to a specific, approved power supply (safety barrier or interface) located in a safe area. See list of safety barriers/interfaces on page 2.

⁽⁴⁾ Refer to the dimensional drawings on the following page.

CONNECTIONS

- Internal and external earthing connection
- The operator can be rotated through 360° to select the most favourable position for cable entry
- Electrical connection between solenoid valve and barrier/interface with cable type A or B according to EN 50039

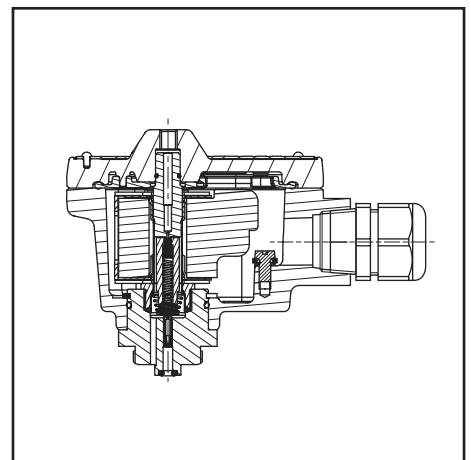

ORDERING INFORMATION

A valve supplied with the intrinsically safe operator will be identified with prefix LI or WSLI before the catalogue number.

Example: **LI G 551A307 24V/DC**

operator — pipe thread — basic number — voltage

OPTIONS

- Cable glands (Nickel-plated brass): unarmoured cable, catalogue number **88200011** / armoured cable, catalogue number **88200014**

RECOMMENDED INTERFACES

Located in safe areas, these interfaces allow to feed the intrinsically safe solenoid valves located in explosive areas. This equipment must be ordered from its respective manufacturers, specifying that they are intended to feed intrinsically safe solenoid operators:

LI / WSLI: II 1G Ex ia IIC T6 Ga, II 2D Ex tb IIIC T85°C IP66/IP67 Db

INTERFACES			
manufacturer	module type	1G/2G T6 IIC	
ABB	DO910S	X	
Bartec	07-7331-2105/1000	X	
	07-7331-2301/1100	X	
		X	
GEORGIN	BXNE701002	X	
	BXNE70100E	X	
G.M. International	D1040Q-2	X	
	D1042Q-2	X	
	D1043Q-2	X	
	D1048S	X	
MTL	MTL 722+	X	
	MTL 728+	X	
	MTL 728P+	X	
Pepperl + Fuchs	KFD2-SL2-Ex1	X	
	KFD2-SL2-Ex1.B	X	
	KFD2-SL2-Ex1.LK	X	
	KFD2-SL2-Ex2	X	
	KFD2-SL2-Ex2.B	X	
	KCD0-SD-Ex1.1245	X	
	KFD0-SD2-Ex2.1245	X	
	LB-2103	FB-2203	X
	LB-2105	FB-2205	X
	LB-2112	FB-2212	X
PHOENIX CONTACT	MACX MCR-EX-SD-24-48-LP-(SP)	X	
	MACX MCR-EX-SD-21-60-LP-(SP)	X	
	PI-EX-SD-24-48	X	
Stahl	9475/12-04-11	9175/20-14-11	X
	9475/12-04-21	9176/10-14-00	X
	9475/12-04-31	9176/20-14-00	X
	9475/32-04-12	9175/10-16-11	X
	9475/32-04-22	9175/20-16-11	X
	9475/32-04-72	9176/10-16-00	X
	9175/10-14-11	9176/20-16-00	X
		9001/01-280-100-101	X
		9002/13-280-110-001	X

INTERFACES		
manufacturer	module type	1G/2G T6 IIC
Turck	MK72-S09-Ex0/24VDC	X
	MC72-41Ex-T/24VDC	X
	MC72-44Ex-T	X
Siemens	6ES7132-7RD11-0AB0 2 ways	X
	6ES7132-7RD21-0AB0	X
	6ES7132-7GD10-0AB0 2 ways	X
	6ES7132-7GD20-0AB0	X

ZENER BARRIERS			
Bartec	07-7331-2301/1001	X	
CEAG	SB-3722	X	
	SB-2420	X	
	SB-3729	X	
	SB-3728	X	
GEORGIN	SB-0728	X	
	BZG728+	X	
	BZG2728+	X	
MTL	BZG728P+	X	
	BZG2728P+	X	
Pepperl + Fuchs	MTL 722	MTL 728P	X
	MTL 728	MTL 779	X
Stahl	Z728	Z728.H	X
	Z728.CL		X
	9001/01-199-150-101		X
	9001/01-280-085-101		X
	9001/01-280-100-101		X
	9001/01-280-110-101		X

In accordance with the zone classification and the national legislation of each country, apply the certification procedures for the connection of IS-rated products with associated equipment. All information subject to change without notice. All responsibility for the use of products from other suppliers and the possible modifications of their characteristics is disclaimed.

DIMENSIONS (mm), WEIGHT (kg)

TYPE LI
 Prefix "LI" Solenoid
 Aluminium, cataphoresis black painting
 IEC and EN: 60079-11, 60079-31
 II 1G Ex ia IIC T6 Ga, II 2D Ex tb IIIC T85°C IP66/IP67 Db

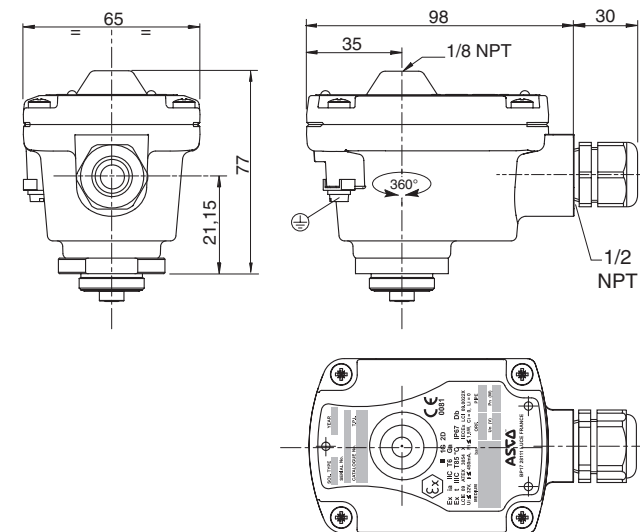

prefix	weight
LI	0,56
WSLI	1,17

TYPE WSLI
 Prefix "WSLI" Solenoid
 Stainless steel
 IEC and EN: 60079-11, 60079-31
 II 1G Ex ia IIC T6 Ga, II 2D Ex tb IIIC T85°C IP66/IP67 Db

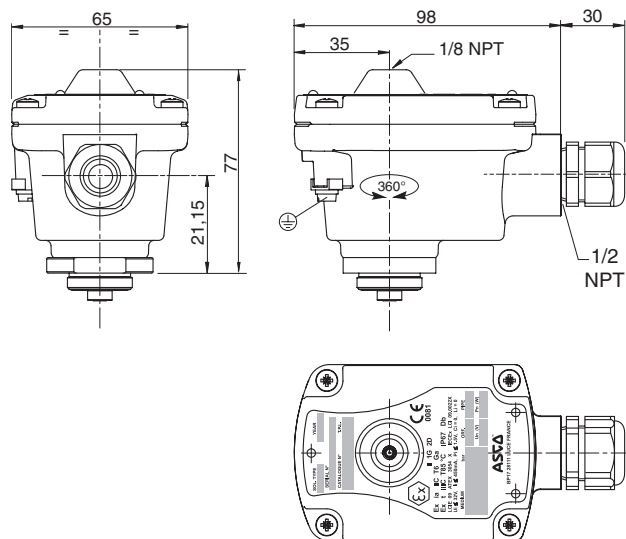

All leaflets are available on: www.asco.com

FEATURES

- Mini-low consumption valves (0,25 W/0,5 W) for use in potentially explosive atmospheres according to ATEX-Directive 2014/34/EU
EC type examination certificate no.: **INERIS 03 ATEX 0249X**
IECEX Certificate of Conformity no.: **IECEX INE 10.0002X**
- Compliance with the Essential Health and Safety Requirements has been assured by compliance with the International and European Standards IEC and EN: 60079-0, 60079-11 and 60079-26
- The valve's Ex ia protection allows it to be installed in explosive atmospheres up to zone 0 or 20. It can be used in the chemical, oil and pharmaceutical industries, or in processing and packaging plants for flammable products (paints, solvents)
- Compact, monobloc pilot valve with spade plug. Connection according to DIN 43650, form C, 9,4 mm pin spacing
- Version with integrated display and electrical protection. LED visible from 3 sides

GENERAL

Differential pressure	0 - 8 bar [1 bar = 100 kPa]
Pneumatic base	ISO 15218 (CNOMO E06.36.120N, size 15)
Connection	Subbase
Response time	20 ms

fluids (*)	temperature range (TS)	seal materials (*)
air or inert gas filtered (50 µm), without condensate, dew point: -20°C	0°C to + 40°C (0,25 W)	NBR (nitrile) FPM (fluoroelastomer)
	- 10°C to + 40°C (0,5 W)	

MATERIALS IN CONTACT WITH FLUID

(*) Ensure that the compatibility of the fluids in contact with the materials is verified

Body	PARA
Internal parts	POM, PET, stainless steel and brass
Seals	NBR, FPM
Pneumatic interface seal	TPE

OTHER MATERIALS

Coil Thermoplastic PET

ELECTRICAL CHARACTERISTICS

Coil insulation class F II 1 G Ex ia IIC T6 to T4 Ga
II 1 D Ex ia IIIC T 85°C to T135°C IP65 Da

Connector	Spade plug (cable Ø 4-6 mm)
Connector specification	DIN 43650, 9,4 mm, form C
Electrical safety	IEC 335
Electrical enclosure protection	Moulded IP65 (EN 60529)
Standard voltages	DC (=) : 12V - 24V ⁽²⁾ (0,25 W = 24 V only)

voltage (U _n) (max. ripple 10%)	power ratings (Pn) ^(*) hot/cold =	typical functional ratings					ambient temperature range (TS)	type ⁽³⁾
		I _(ON) min. with LED	U _(ON) min.	U _(MAX) recom- mended	U _(OFF) turn off	I _(OFF) turn off		
(V)	(W)	(mA)	(V)	(V)	(V)	(mA)	(°C) ⁽¹⁾	01
LP1 "24V"	0,25	20	12,2	28	3,3	7	0 to +40/50/60	
LP1 "12V"	0,5	33	11,9	23	3,3	10	-10 to +40/50/60	
LP1 "24V"		25	16,4	28	5,7	7		

^(*) Nominal power ratings of standard versions (with LED indicator and electrical protection)

Pn	safety parameters				
	U _i = (DC)	I _i	P _i	L _i	C _i
(W)	(V)	(mA)	(W)	(mH)	(µF)
0,25/0,5	28	300	1,6	0	0

Example of use with a Zener barrier installed in a non-hazardous zone:
safe area (RS interface) cable explosive area

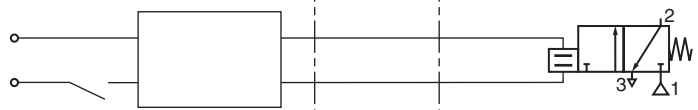

TEMPERATURE CLASSIFICATION TABLES DC (=)

Pi (watt)	maximum ambient °C ⁽¹⁾					
	surface temperature					
	T6 85°C		T5 100°C		T4 135°C	
	12V	24V	12V	24V	12V	24V
1,6	40	40	50	60	60	60
	-	-	-	-	50	50

Insulation class F (155°C) 100% E.D. ⁽²⁾

single solenoid valve
solenoid valve mounted in series

- ⁽¹⁾ Minimum ambient temperature: 0°C (0,25 W) / -10°C (0,5W)
⁽²⁾ Coil designed for permanent duty within maximum ambient temperature limits. The solenoid valve must be connected to a special certified electrical supply unit installed in a non-dangerous zone. List of safety barrier manufacturers on the following page.
⁽³⁾ Refer to the dimensional drawings on the page 4.

SPECIFICATIONS

orifice size	flow				operating pressure differential (bar)		power coil (W)	basic catalogue number
	at 6,3 bar l/min (ANR)		coefficient Kv		min.	max. (PS)		with impulse /maintained manual operator
(mm)	1 → 2	2 → 3	1 → 2	2 → 3		(=)	(=)	=
3/2 NC - normally closed (With LED and protection)								
0,6	4	11	0,04	0,16	0	8	0,25	30215311AD
	11	20	0,21	0,44	0	8	0,5	30215106AD

When ordering, please specify in addition to the basic catalogue number:

- voltage:
- 0,25 W: 24 V DC
- 0,5 W: 12 V DC or 24 V DC

Examples: with connector DIN 43650, 9,4 mm: **30215311AD** 24V DC
 with connector DIN 43650, 9,4 mm: **30215106AD** 12V DC
 with connector DIN 43650, 9,4 mm: **30215106AD** 24V DC

OPTIONS

- Solenoid valves without LED and electrical protection (0,5 W only)

INSTALLATION

- The solenoid valves can be mounted in any position without affecting operation
- Solenoid valve supplied with mounting screws and mounting pad seal(s)
- Electrical connection between solenoid valve and barrier/interface with cable type A or B according to EN 50039
- Installation on single subbase (3 x M5), brass body, catalogue number **30300001**
- Versions with spade-plug connector type ISO 15217/DIN 43650 form C with 8 mm spacing or M12 connection: contact us
- Installation/maintenance instructions are included with each valve

See the list for compatible interfaces and barriers.

This list is for reference only and the user must take into account the cables and the actual supply voltages for the barriers.

The operating conditions are calculated as follows:

0,25 W: **24 V with LED**

$$I_1 \text{ (mA)} = \frac{[V_s - 1,2 - 0,002 (R_b + R_1)] \times 1000}{(R_c + R_1 + R_b)} + 2$$

0,5 W: **12 V or 24 V with LED**

$$I_1 \text{ (mA)} = \frac{[V_s - 1,2 - 0,003 (R_b + R_1)] \times 1000}{(R_c + R_1 + R_b)} + 3$$

This value and the maximum barrier/interface current (if it is non-linear) must be greater than 33 mA (12 V with LED), 25 mA (24 V with LED, 0,5 W), 20 mA (24 V with LED, 0,25 W).

I_1 (mA) Min. supply current of the product

R_b (Ω) Max. barrier resistance

T_a (°C) Max. ambient temperature

R_1 (Ω) Max. resistance of connecting cables

V_s (V) Min. no-load voltage of barrier/interface

R_c (Ω) Max. coil resistance:

$$12 \text{ V with LED} = \frac{288 (T_a + 234 + 10)}{254} \quad / \quad 24 \text{ V with LED} = \frac{563 (T_a + 234 + 10)}{254}$$

COMPATIBLE BARRIERS AND INTERFACES

The 12 V DC and 24 V DC solenoid valves are compatible with the barriers listed in the table below.

0,5 W: The index (1) indicated the 12 V DC versions that are compatible with the 24 V DC barriers.

Located in safe areas, these barriers and interfaces allow to feed the intrinsically safe solenoid valves located in explosive areas. This equipment must be ordered from its respective manufacturers, specifying that they are intended to feed intrinsically safe solenoid valves: 302 1. ...IA., II 1 G Ex ia IIC T6 to T4 Ga, II 1D Ex ia IIIC T85°C to T135°C IP6X Da.

0,5 W				0,5 W			
INTERFACES				ZENER BARRIERS			
manufacturer	module type	302 Ex ia		manufacturer	module type	302 Ex ia	
		12 V with LED	24 V with LED			12 V with LED	24 V with LED
ABB	DO910S	x	x	CEAG	SB-3722	x	
AP3	NAEV30-DO2C-A230-0	x			SB-0722		
	NAEV30-DO2C-A115-0	x			SB-2420	x	x
	NAEV30-DO2H-C024-0	x			SB-3729	x	x
	NAEV30-DO4H-C024-0	x			SB-3728	x	x
	NAEV30-DI2-DO1C-A230-0	x			SB-0728	x	
	NAEV30-DI2-DO1C-A115-0	x		SB-0728	x		
	NAEV30-DI2-DO1H-C024-0	x		MTL	MTL 722	x	
Bartec	07-7331-2105/1000	x		MTL 728	x	x	
	07-7331-2301/1100	x		MTL 728P	x	x	
CEAG	LB-2101			MTL 779	x	x	
	LB-2103			Pepperl + Fuchs	Z728	x	x
	LB-2105	x		Z728.H	x	x	
	LB-2112	x	x	Z728.CL	x	x	
	FB-2201			Stahl	9001/01-199-150-101	x	
	FB-2203	x			9001/01-280-075-101		
	FB-2205	x			9001/01-280-085-101	x	x
FB-2212	x	x	9001/01-280-100-101		x	x	
G.M. international	D1040Q-2	x		9001/01-280-110-101	x	x	
	D1042Q-2	x	x	EMERSON	DELTA V		x
	D1043Q-2	x					
MTL	815-DO-04	x	x				
	4021S	x					
Pepperl + Fuchs	KFD2-SD-Ex1.17	x					
	KFD2-SD-Ex1.36	x	x				
	KFD2-SD-Ex1.48	x ⁽¹⁾					
	KFD2-SD-Ex1.48.90A	x ⁽¹⁾					
	KFD2-SL-Ex1.48	x ⁽¹⁾					
	KFD2-SL-Ex1.48.90A	x ⁽¹⁾					
	KFD2-SL2-Ex1	x ⁽¹⁾	x				
	KFD2-SL2-Ex1.B	x ⁽¹⁾	x				
	KFD2-SL2-Ex1.LK	x ⁽¹⁾	x				
	KFD2-SL2-Ex2	x ⁽¹⁾	x				
	KFD2-SL2-Ex2.B	x ⁽¹⁾	x				
Stahl	KFD2-VD-Ex1.1560	x					
	KFD2-VD-Ex1.1835	x	x				
	9475/12-04-11	x					
Turck	9475/12-04-21	x	x				
	9475/12-04-31	x					
	MK72-S01-Ex	x					
	MK72-S09-Ex0/24VDC	x					
	MK72-S10-Ex0/24VDC	x					
	MC72-41Ex-T/24VDC	x					
	MC72-42Ex-T/24VDC		x				
Siemens	MC72-44Ex-T	x					
	MC72-43Ex-T		x				
	ET2001S double	x	x				
	6ES7132-7RD20-OAB0	x					

Not compatible ⁽¹⁾ Compatible with 24 V DC

For other compatible barriers and interfaces, please ask our product support.

In accordance with the zone classification and the national legislation of each country, apply the certification procedures for the connection of IS-rated products with associated equipment. All information subject to change without notice. All responsibility for the use of products from other suppliers and the possible modifications of their characteristics is disclaimed.

0,25 W			0,25 W		
INTERFACES			INTERFACES		
manufacturer	module type	302 Ex ia	manufacturer	module type	302 Ex ia
		24 V with LED			24 V with LED
ABB	DO910S	x	Turck	DO040Ex	x
EMERSON (EPM)	DELTA V	x	Pepperl + Fuchs	FB 2201	x
MTL	815-DO-04	x		FB 2202	x
Siemens	6E S7132-5SB00-OAB0	x		FB 2203	x
	6E S7132-5SB00-OAB0 2 way	x		FB 2204	x
	6E S7132-7RD00-OAB0	x		FB 2205	x
	6E S7132-7RD10-OAB0	x		FB 2212	x
	6E S7132-7RD10-OAB0 2 way	x		FB 6210B	x
	6ES7132-7RD20-OAB0	x		FB 6211B	x
Stahl	6E S7132-7RD20-OAB0 2 way	x		FB 6212B	x
	9475/12-04-11	x		FB 6213B	x
	9475/12-04-21	x		FB 6214B	x
	9475/12-04-31	x	FB 6215B	x	
	9475/12-08-51	x			
	9475/12-08-61	x			

For other compatible barriers and interfaces, please ask our product support.

All leaflets are available on: www.asco.com

DIMENSIONS (mm), WEIGHT (kg)



TYPE 01

IEC 335 / DIN 43650
 EN/IEC 60079-11/26
 II 1 G Ex ia IIC T6 to T4 Ga
 II 1 D Ex ia IIIC T85°C to T135°C IP65 Da

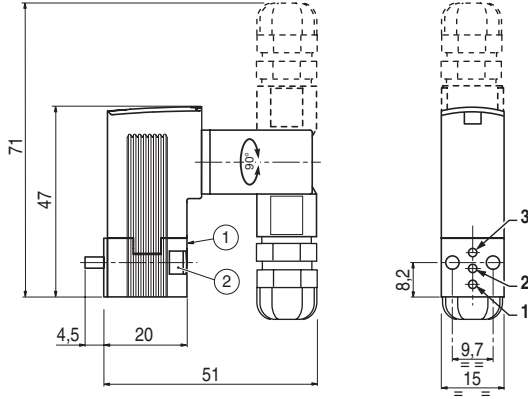

Pneumatic base: ISO 15218
 (CNOMO E06.36.120N, size 15)

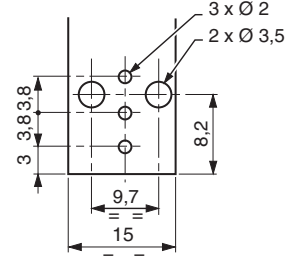

type	weight ⁽¹⁾
01	0,052

- ① Manual operator location
- ② Mounting: 2 M3 x 20 screws

⁽¹⁾ Including connector.

Single subbase Brass

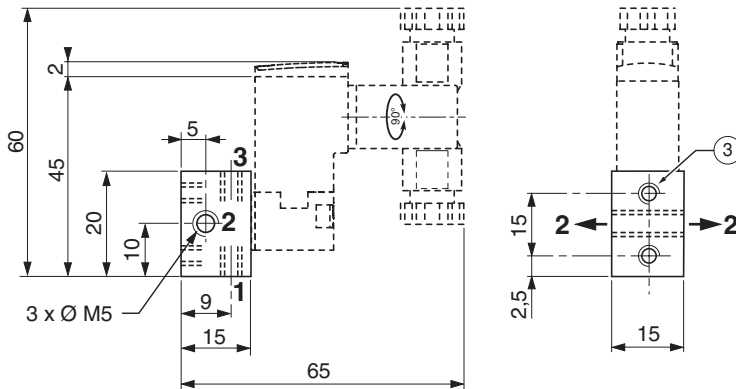
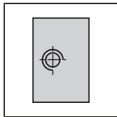

- ③ Mounting: 2 holes M3, depth 4,5
- Orifice (2) can be connected on the left or on the right of the subbase.

material	catalogue number	weight ⁽¹⁾
brass	30300001	0,034

⁽¹⁾ subbase alone



SOLENOID VALVES

intrinsically safe

II 1G Ex ia IIC T6 Ga, II 2D Ex ib IIIC T85°C Db IP67
ISO 15218 (CNOMO, size 30) interface
direct operated, pad mounting body



NC

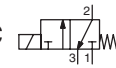

3/2
Series

195/LISC



FEATURES

- Low consumption valves for use in potentially explosive atmospheres according to ATEX-Directive 2014/34/EU
EC type examination certificate no.: **DEKRA 11 ATEX 0091 X**
IECEX Certificate of Conformity no.: **IECEX DEK 11.0038X**
- Compliance with the Essential Health and Safety Requirements has been assured by compliance with the International and European Standards IEC and EN: 60079-0 and 60079-11
- The valve's Ex ia protection allows it to be installed in explosive atmospheres up to zone 1. It can be used in the chemical, oil and pharmaceutical industries, or in processing and packaging plants for flammable products (paints, solvents)
- Compact, monobloc pilot valve with spade plug connection according to ISO 4400 / EN 175301-803, form A (3 pins)
- This solenoid valve can be mounted as operator onto valve 551-553 series SIL3 capable (EXIDA approval)

GENERAL

Differential pressure

2 - 10 bar [1 bar = 100 kPa]

Flow

conforming to ISO 6358

See «SPECIFICATIONS»

$C = 3 \times 10^{-10} \text{ m}^3/\text{s} \cdot \text{Pa}$ (sonic conductance)

$b = 0,4$ (critical pressure ratio)

ISO 15218 (CNOMO E06.05.80N, size 30)

Pneumatic base

11 ms

Response time

fluids (*)	temperature range (TS)	seal materials (*)
air or inert gas dry, filtered (50 µm), without condensate, dew point: -20°C	-40°C to +65°C	FPM (fluoroelastomer)

MATERIALS IN CONTACT WITH FLUID

(*) Ensure that the compatibility of the fluids in contact with the materials is verified

Body

Aluminium

Internal parts, core tube

Stainless steel

Seals

FPM

Subbase

PA or zamak

OTHER MATERIALS

Coil

Thermoplastic resin

ELECTRICAL CHARACTERISTICS

Coil insulation class

F

SAFETY CODE (1)

Ex II 1G Ex ia IIC T6 Ga

II 2D Ex ib IIIC T 85°C Db IP67

⚠ (1) For use in zone 0 locations, see the installation conditions given in the I&M instructions.

Connector

Spade plug (cable Ø 6-8 mm)

Connector specification

ISO 4400 / EN 175301-803, form A

Electrical safety

IEC 335

Electrical enclosure protection

Moulded IP65 (EN 60529)

Standard voltages

DC (=) : 12V .. 24V

voltage (U _n) (max. ripple 10%)	typical functional ratings			R 20°C	operator ambient temperature range (TS)	type (3)
	I _(ON) min.	U _(ON) min.	P _(ON) min.			
(V)	(mA)	(V)	(W)	(Ω)	(°C) (1)	
24	36	12,8	0,46	240	-40 to +65	01

safety parameters				
U _i = (DC)	I _i	P _i	L _i	C _i
(V)	(mA)	(W)	(H)	(µF)
30	300	1,6	0	0

safe area (RS interface)

explosive area

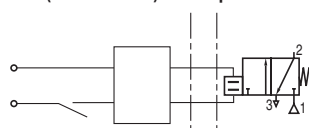

Example of use with a Zener barrier installed in a non-hazardous zone

TEMPERATURE CLASSIFICATION TABLES DC (=)

Pi (watt)	maximum ambient °C (1)	
	surface temperature	
	T6 85°C	
Insulation class F (155°C) 100% E.D. (2)		
1,6	65	

(1) The minimum allowable ambient temperature is -40°C

(2) This intrinsically safe valve must be connected to a specific, approved power supply (safety barrier or interface) located in a safe area. See list of safety barriers/interfaces on page 2.

(3) Refer to the dimensional drawings on the following page.

SPECIFICATIONS

pipe size	orifice size		flow				operating pressure differential (bar)		power coil (W)	catalogue number
	1 → 2 (mm)	2 → 3 (mm)	at 6 bar l/min (ANR)		coefficient Kv (l/min)		min.	max. (PS) air (*)		without manual operator
			1 → 2	2 → 3	1 → 2	2 → 3		=	=	
NC - Normally closed										
pad mounting	0,5	0,7	8	15	0,11	0,26	2	10	0,46	19500036

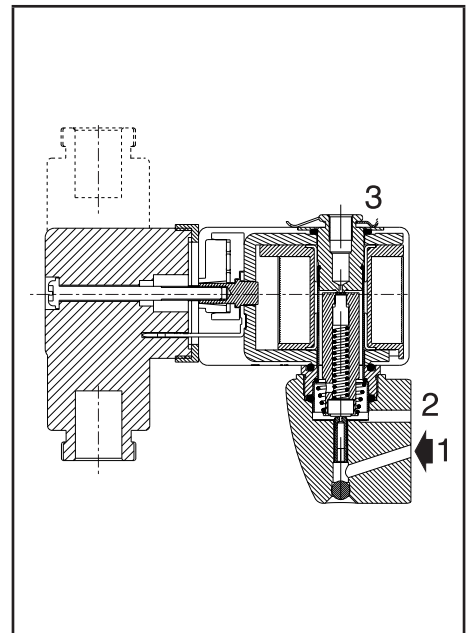

SUBBASES

pipe size	designation	safety code	catalogue number
6/6 polyamide subbases			
instant fittings ⁽¹⁾	single subbase (instant fittings OD 4 mm)	II 2 GD c Ta 50°C T 85°C (T6)	35300069
Zamak subbases			
G 1/8 ⁽¹⁾ , tapped	laterally-connected single subbase	II 2 GD c Ta 50°C T 85°C (T6)	35300047

⁽¹⁾ These subbases can be mounted on omega rail to EN 50022 using 2 clips (clips sold in packs of 10, catalogue number: **33400036**).

OPTIONS

- Joinable subbases

INSTALLATION

- The solenoid valves can be mounted in any position without affecting operation
- Solenoid valve supplied with mounting screws
- Pipe connections G 1/8 have standard thread according to ISO 228/1
- Electrical connection between solenoid valve and barrier/interface with cable type A or B according to EN 50039
- Installation/maintenance instructions are included with each valve

RECOMMENDED INTERFACES

Located in safe areas, these interfaces allow to feed the intrinsically safe solenoid valves located in explosive areas. This equipment must be ordered from its respective manufacturers, specifying that they are intended to feed intrinsically safe solenoid valves 19500036/LISC: II 1G Ex ia IIC T6 Ga, II 2D Ex ib IIIC T85°C Db IP67

INTERFACES		
manufacturer	module type	IIC / IIIC
Bartec	07-7331-2301/1001	x
ABB	DO910S	x
GEORGIN	BXNE711002	x
	BXNE71100E	x
G.M. International	D1040Q-2	x
	D1042Q-2	x
	D1048S	x
	D1049S	x
	D5048S	x
MTL	D5049S	x
	MTL5522	x
	MTL5521	x
Pepperl + Fuchs	MTL4524S	x
	KFD2-SD-Ex1.36	x
	KFD2-SL2-Ex1	x
	KFD2-SL2-Ex1.B	x
	KFD2-SL2-Ex1.LK	x
	KFD2-SL2-Ex2	x
	KFD2-SL2-Ex2.B	x
	KCD0-SD-Ex1.1245	x
	KFD0-SD2-Ex2.1245	x
	HIC2871	x
Siemens	LB-2112	x
	FB-2212	x
	6ES7132-7RD11-0AB0 2 ways	x
	6ES7132-7RD22-0AB0 2 ways	x
	6ES7132-7GD10-0AB0 2 ways	x
	6ES7132-7GD20-0AB0 2 ways	x
	ET200IS double	x
Stahl	6ES7132-7RD10-0AB0 2 ways	x
	6ES7132-7RD20-0AB0 2 ways	x
	9475/12-04-11	x
	9475/12-04-21	x
	9475/22-04-21	x
	9475/32-04-12	x
	9475/32-04-22	x
	9475/32-04-72	x
	9175/10-14-11	x
	9175/20-14-11	x
Turck	9176/10-14-00	x
	9176/20-14-00	x
WAGO	9001/01-280-100-101	x
	MC72-41Ex-T/24VDC	x
	MC72-44Ex-T	x
	750-535	x

ZENER BARRIERS		
manufacturer	module type	IIC / IIIC
CEAG	SB-3722	x
	SB-2420	x
	SB-3729	x
	SB-3728	x
MTL	MTL 728	x
	MTL 728P	x
	MTL 779	x
Pepperl + Fuchs	Z728	x
	Z728.H	x
	Z728.CL	x
Stahl	9001/01-280-085-101	x
	9001/01-280-100-101	x
	9001/01-280-110-101	x

In accordance with the zone classification and the national legislation of each country, apply the certification procedures for the connection of IS-rated products with associated equipment. All information subject to change without notice. All responsibility for the use of products from other suppliers and the possible modifications of their characteristics is disclaimed.

ORDERING EXAMPLES:

basic number	19500036	.	12..24V / DC	voltage
--------------	----------	---	--------------	---------

All leaflets are available on: www.asco.com

20 - Explosionproof equipment



青岛集诚自动化设备有限公司
地址：中国·青岛市重庆南路99号海尔云街甲3号楼7F

服务热线：4006-918-365
网址：http://www.asco.store

传真：(86-532)585-10-365
Email：sales@bechinas.com

DIMENSIONS (mm), WEIGHT (kg)



TYPE 01

Spade plug
IEC 335 / DIN 43650
II 1G Ex ia IIC T6 Ga
II 2D Ex ib IIC T85°C Db IP67

19500036

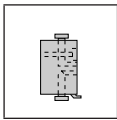
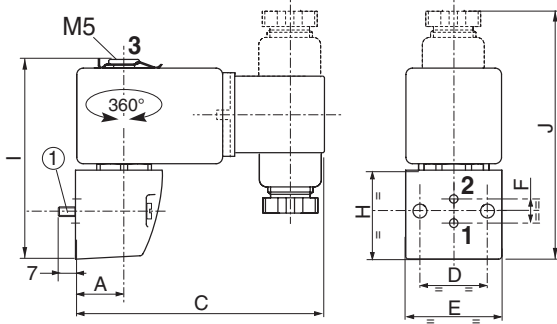

TYPE 02

Single instant fitting subbase
Polyamide

35300069

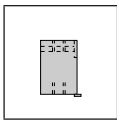
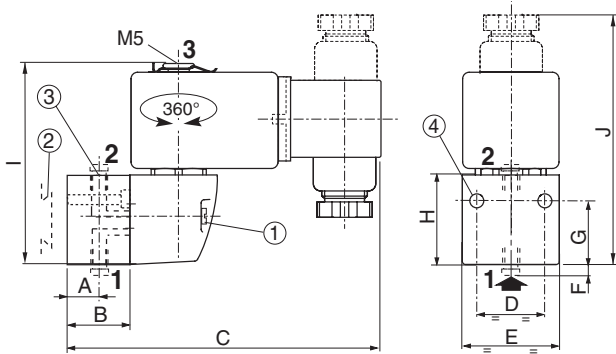

TYPE 03

Single subbase
Zamak

35300047

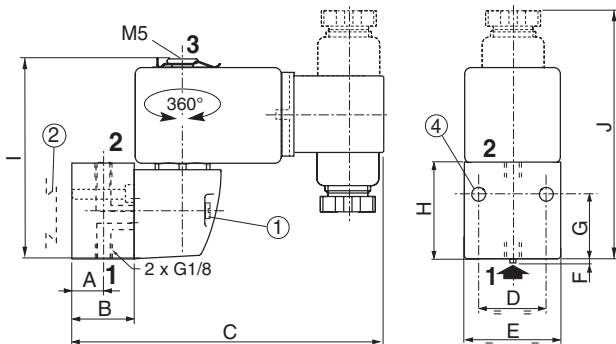

type	catalogue number	A	B	C	D	E	F	G	H	I	J	weight ⁽²⁾
01	19500036	15,5	-	79	21	30	7,5	15	30	63	75	0,22
02	35300069	13	20	99	23	33	4	22,5	30	67	80	0,20
03	35300047	15	25	104	21	31	3,5	30	36	70	83	0,20

⁽²⁾ Incl. coil(s) and connector(s).

- ① Mounting: two CM 4 x 35 screws
- ② Adaptable clips
- ③ Instant-fitting connection for OD 4 mm tube
- ④ Two dia. 3,5 mm securing holes

01056GB-2017/R01
Availability, design and specifications are subject to change without notice. All rights reserved.

Consulter notre documentation sur : www.asco.com

ACCESSORIES

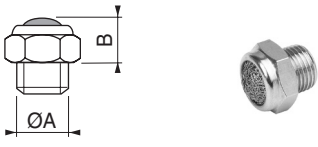
	
ØA	M5
B	4,5
exhaust protector (stainless steel) catalogue number: 34600484	



MINI-SOLENOID VALVES

non-sparking protection
 II 3G Ex nA IIC T6..T4 Gc, II 3D Ex tc IIIC IP65 T85°C..T135°C Dc
 ISO 15218 (CNOMO, size 15) interface
 direct operated, pad mounting body, connector size 15

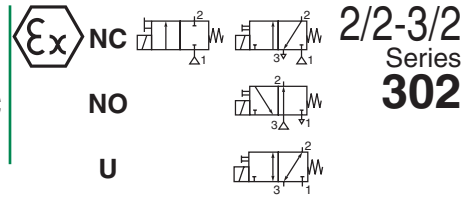

FEATURES

- Mini-low consumption valves for use in potentially explosive atmospheres according to ATEX-Directive 2014/34/EU
 EC type examination certificate no.: **INERIS 10 ATEX 3016X**
- Compliance with the Essential Health and Safety Requirements has been assured by compliance with European Standards EN 60079-0, EN 60079-15 and EN 60079-31
- Compact, monobloc solenoid pilot valve with spade-plug connector type DIN 43650, form C with 9,4 mm spacing
- Version without integrated LED and electrical protection
- Universal version for vacuum operation (3/2 way)

GENERAL

Differential pressure See «SPECIFICATIONS» [1 bar = 100 kPa]
Pneumatic base ISO 15218 (CNOMO E06.36.120N, size 15)
Connection Subbase
Response time 8 - 15 ms

fluids (*)	temperature range (TS)	seal materials (*)
air or inert gas filtered at 50 µm, lubricated or not	- 25°C to + 40°C (LP2) ⁽¹⁾	NBR (nitrile) FPM (fluoroelastomer)

⁽¹⁾ LP2: see "electrical characteristics" table

MATERIALS IN CONTACT WITH FLUID

(*) Ensure that the compatibility of the fluids in contact with the materials is verified

Body PARA
Internal parts POM, PET, stainless steel and brass
Seals NBR (disc), FPM (others)
Pneumatic interface seal TPE

OTHER MATERIALS

Coil Thermoplastic PET
Enclosure with PVC cable PP (polypropylene) glass-fibre reinforced

ELECTRICAL CHARACTERISTICS

Coil insulation class F **SAFETY CODE**
 II 3G Ex nA IIC T6..T4 Gc
 II 3D Ex tc IIIC IP65 T 85°C..T 135°C Dc

Connector Spade plug (2m cable length)
Connector specification DIN 43650, 9,4 mm, form C
Electrical safety IEC 335
Electrical enclosure protection Moulded IP65 (EN 60529)
Standard voltages DC (=): 24V
 (Other voltages on request) AC (-): Contact us

power ranges	coils	voltages	power ratings	max. ambient temperature °C ⁽²⁾			type ⁽⁴⁾
				surface temperature			
				hot/cold =	T6	T5	
		=	(W)	85°C	100°C	135°C	
LP2 ⁽³⁾	24		1 / 1,2	40	55	60	01

⁽⁴⁾ Refer to the dimensional drawings on the following page.

SPECIFICATIONS

orifice size (mm)	flow				operating pressure differential (bar)		power ranges	basic catalogue number			
	at 6 bar l/min (ANR)		coefficient Kv		min.	max. (PS)		manual operator			
	1 → 2	2 → 3	1 → 2	2 → 3				impulse	maintained		
2/2 NC - Normally closed (Without LED and protection)											
1,5	39	-	0,50	-	0	3	LP2	-	30211022NAD	-	30211023NAD
3/2 NC - normally closed (Without LED and protection)											
0,6	11	20	0,11	0,26	0	10	LP2	-	30211109NAD	-	30211110NAD
0,8	17	28	0,22	0,35	0	8	LP2	-	30211112NAD	-	30211113NAD
1,1	32	51	0,35	0,50	0	5	LP2	-	30211118NAD	-	30211119NAD
1,5	39	53	0,50	0,56	0	3	LP2	-	30211124NAD	-	30211125NAD
	3 → 2	2 → 1	3 → 2	2 → 1							
3/2 NO - normally open (Without LED and protection)											
0,8	20	17	0,26	0,20	0	8	LP2	-	30211130NAD	-	-
1	28	32	0,35	0,35	0	5	LP2	-	30211136NAD	-	-
1,5	53	39	0,56	0,50	0	2	LP2	-	30211142NAD	-	-
	1 ↔ 2	2 ↔ 3	1 ↔ 2	2 ↔ 3							
3/2 U - universal (Without LED and protection)											
0,8	17	20	0,20	0,26	0	6	LP2	-	30211148NAD	-	30211149NAD

When ordering, please specify, in addition to the basic catalogue number, the type of current: voltage

Examples: 24V DC: **30211009NAD** 24V DC

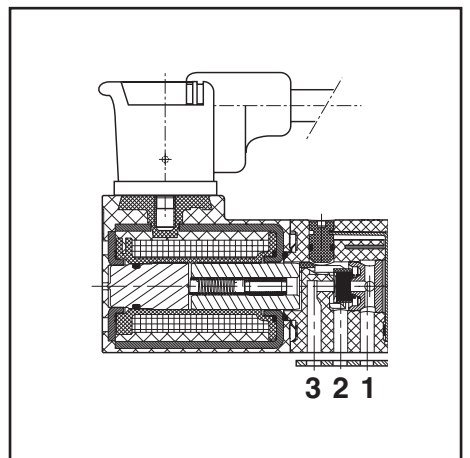

For versions with LED indicator and electrical protection:
 Contact us
⁽²⁾ The minimum allowable ambient temperature is -25°C. Actual temperature range can be limited depending on valve operation limits.
⁽³⁾ Voltage: -15% / +20%

00166GB-2017/R01 Availability, design and specifications are subject to change without notice. All rights reserved.



青岛秉诚自动化设备有限公司
 地址：中国·青岛市重庆南路99号海尔云街甲3号楼7F

服务热线：4006-918-365
 网址：http://www.asco.store

All leaflets are available on: www.asco.com

Explosionproof equipment - 23
 传真：(86-532)585-10-365
 Email：sales@bechinas.com

OPTIONS AND ACCESSORIES

- Seals and disc made of FPM (fluoroelastomer)
- Version without manual operator
- Version with pneumatic-electric interface

INSTALLATION

- The solenoid valves can be mounted in any position without affecting operation
- **Pre-wired connector, supplied and certified with the product (DIN 43650, 9,4 mm, form C, with 2 m cable length). For connection, only use the connector supplied with the product**
- Solenoid valve supplied with mounting screws and mounting pad seal(s)
- Installation/maintenance instructions are included with each valve

DIMENSIONS (mm), WEIGHT (kg)



TYPE 01
IEC 335 / DIN 43650
IP65

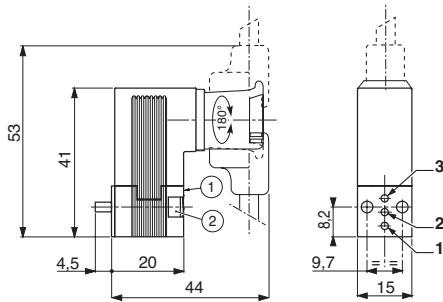

- ① Manual operator location
- ② 2 mounting screw M3 x 20

function	connection			
	1	2	3	
2/2 way				
	NC	P	U	-
3/2 way				
universal	NC	P	U	E
	NO	E	U	P
	MIX	P2	U	P1
	SEL	U 2	P	U 1

P: Pressure U: Outlet
E: Exhaust

Subbase mounting surface: ISO 15218
(CNOMO E06.36.120N, size 15)

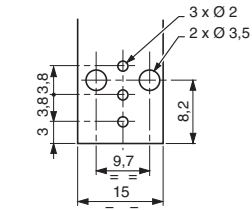

weight ⁽¹⁾
0,14

⁽¹⁾ with connector.

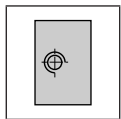

Single subbase
Aluminium or brass

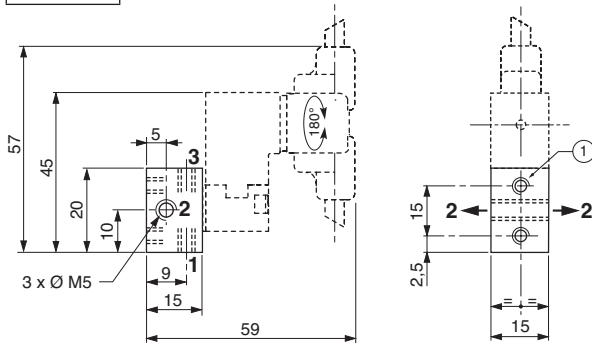

- ① Mounting: 2 holes M3, depth 4,5
- Orifice (2) can be connected on the left or on the right of the subbase.

material	catalogue number	weight ⁽¹⁾
aluminium	88263002	0,011
brass	30300001	0,034

⁽¹⁾ subbase alone

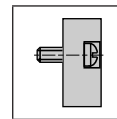

Adapter CNOMO size 30
(only for NC version)
Aluminium

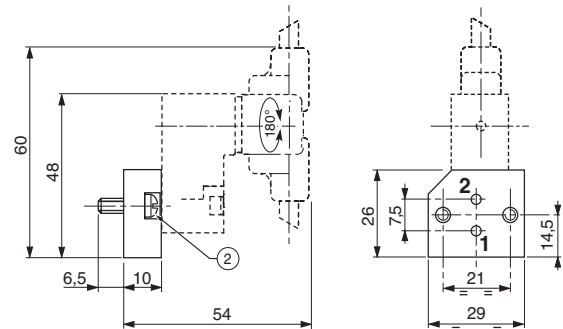

- ② Mounting: 2 screws M4 x 10 (supplied)

catalogue number	weight ⁽²⁾
88263001	0,018

⁽²⁾ adapter alone

FEATURES

- Explosionproof operator for use in dust application with potentially explosive atmospheres according to ATEX-Directive 2014/34/EU
- Compliance with the Essential Health and Safety Requirements has been assured by compliance with the European Standards EN 60079-0 and EN 60079-31
- The assembly consisting of the coil and connector has IP65 protection
- The operators are designed for installation on a wide range of valves
- Available series: 189-189 banjo-190-238-256-262-263-314-356-541-541 compact-542-543-551-553-353-355 [Dust Collector Systems (DCS)]

CONSTRUCTION

Coil	Epoxy encapsulated
Connector enclosure	Glass-fibre filled PA
Connector specification	
size 22 (11 mm)	EN 175301-803 industry standard form B
size 30 (18 mm)	ISO 4400 / EN 175301-803, form A
Core tube & Plugnut	Stainless steel
Nameplate	Polyester
Safety code	SG (solenoid valves): ⊕ II 3 D, Ex tc IIIC T115°C Dc IP65X SG (Dust Collector Systems): ⊕ II 3 D, Ex tc IIIC T110°C Dc IP65X]
Seals	FPM o-ring, EPDM gasket



ELECTRICAL CHARACTERISTICS

(Other voltages and 60 Hz on request) DC (=) : 12V - 24V - 48V - 110V
AC (~) : 24V - 48V - 115V - 230V / 50 Hz

Number of contacts	Size 22	Size 30
	2 + common earth	2 + common earth
Distance between contacts	11 mm	18 mm
Connector	Spade plug (cable Ø 4,5-7 mm)	Spade plug (cable Ø 4,5-10 mm)
Electrical safety	IEC 335	IEC 335
Electrical enclosure protection	IP65 (EN 60529)	IP65 (EN 60529)
Number of wires (with cable)	3 x ≤ 1,5 mm ²	3 x ≤ 1,5 mm ²

	max. AC power (W)	max. DC power (W)
SG	17,1	11,6
DCS	11,1	21,2

TEMPERATURE CLASSIFICATION TABLES

	surface temperature	min. ambient temperature	max. ambient temperature	E.D. ⁽¹⁾
SG	115°C	-10°C	+50°C	100%
DCS	110°C	-10°C	+60°C	10%

⁽¹⁾ Duty factor.

ORDERING EXAMPLES

A valve with the explosionproof operator will be identified:

Series 189, 189 banjo, 190, 541, 541 compact, 542, 543	Series 238 (3/8 to 1), 256, 356, 551 (integrated pilot), 553, 353 (DCS)
With cable gland connector	
SG 54100883 . 230 / 50 SG 19000006 . 24 / DC SG 18900001 . 230 / 50-60 SG 18900047 . 230 / 50-60	SG E238D001 . 230 / 50-60 SG G256B002VMS . 115 / 50-60 SG G353A047 . 24 / DC SG G551A001MS . 230 / 50-60
option code for ATEX compliance (prefix) _____ solenoid valve catalogue number _____ voltage _____	option code for ATEX compliance (prefix) _____ solenoid valve basic number _____ voltage _____

Series 262, 263, 314						
15-DIGIT PRODUCT CODE						
E	262	K	232	SG	V00	H1
E	263	K	232	SG	V00	F8
Thread connection	Product series	Revision letter	Valves version	Electrical interface	Voltage - class	
					Options	

All leaflets are available on: www.asco.com

01059GB-2017/R01 Availability, design and specifications are subject to change without notice. All rights reserved.

INSTALLATION

- The package consists of the solenoid valve, the coil (installed) and the connector (not installed)
- The coil is provided with an earthing connection
- Additional protection is necessary to protect the coil against mechanical stress and UV radiation
- Easy connection with spade plug connector
- Installation/maintenance instructions are included with each coil
- The spare part coil is always delivered with the connector in a unique reference

DIMENSIONS (mm), WEIGHT



TYPE 01

Coil + connecteur taille 22 (11 mm)
EN 175301-803 standard industriel forme B
IP65

Série (XM5): 189, 189 banjo, 256, 238 (3/8..1), 353 (DCS),
355B6 (DCS), 356, 541, 541 compact, 542, 543, 551

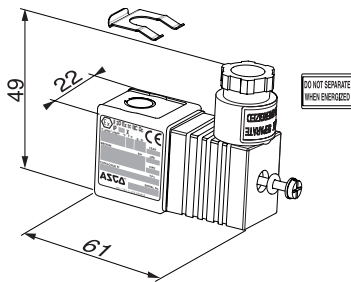

TYPE 02

Coil + connector size 30 (18 mm)
ISO 4400 / EN 175301-803, form A
IP65

Series (C25): 190, 238 (3/8..1), 256 (1/4), 356 (1/4), 541,
542, 543, 553

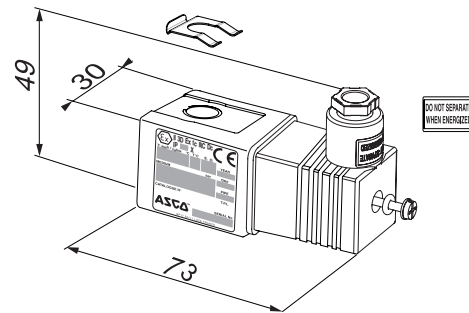

TYPE 03

Coil + connector size 30 (18 mm)
ISO 4400 / EN 175301-803, form A
IP65

Series (M6 II): 262, 263, 314, 353 (DCS), 355B8 (DCS)

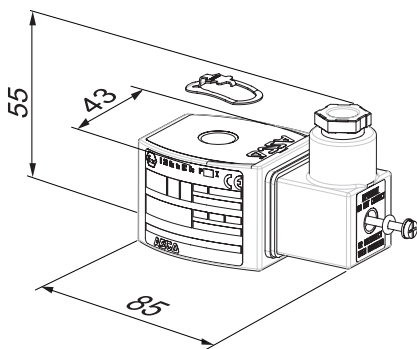

TYPE 04

Coil + connector size 30 (18 mm)
ISO 4400 / EN 175301-803, form A
IP65

Series (MXX-II) 262, 263, 314, 353 (DCS)

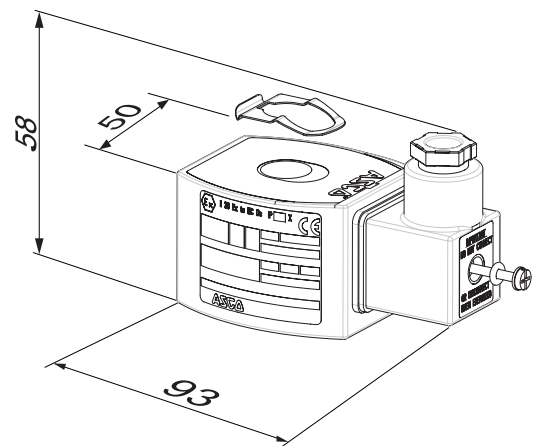

type	weight (kg)
XM5	0,092
C25	0,156
M6-II	0,286
MXX-II	0,376

All leaflets are available on: www.asco.com

26 - Explosionproof equipment



青岛秉诚自动化设备有限公司
地址：中国·青岛市重庆南路99号海尔云街甲3号楼7F

服务热线：4006-918-365
网址：<http://www.asco.store>

传真：(86-532)585-10-365
Email：sales@bechinas.com

FEATURES

- Explosionproof material intended for use in potentially explosive atmospheres according to ATEX-Directive 2014/34/EU
EC type examination certificate no.: **INERIS 12 ATEX 0032 X**
IECEX Certificate of Conformity no.: **IECEX INE 12.0025 X**
- Compliance with the Essential Health and Safety Requirements has been assured by compliance with the International and European Standards EN-IEC 60079-0, EN-IEC 60079-1 and EN-IEC 60079-31
- Cable glands for armoured and unarmoured cables can be fitted to Ex d operators

GENERAL

	1/2 NPT	3/4 NPT
Protection, unarmoured cable	IP68 (10 bar), on outer sheath	IP68 (10 bar), on outer sheath
Protection, armoured cable	IP68 (10 bar), on outer/inner sheath 0 to 1,25 mm armour I.D. 7 to 12 mm I.D. 13,5 to 20,5 mm O.D. 10 to 16 mm I.D. 7 to 12 mm	IP68 (10 bar), on outer/inner sheath - I.D. 10 to 16 mm - O.D. 13,5 to 21 mm I.D. 10 to 15,5 mm

Unarmoured cable

Armoured cable

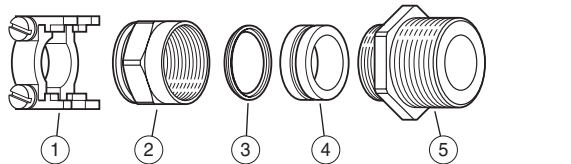

- ① cable clamp ③ backup ring ⑤ adapter (1/2 or 3/4 NPT)
② nut ④ grommet

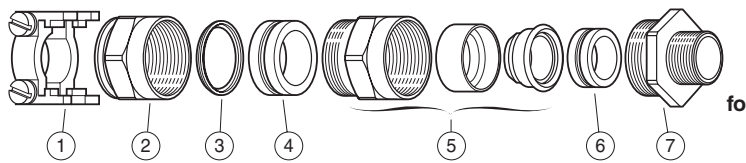

- ① cable clamp ④ grommet (internal sealing) ⑦ adapter (1/2 or 3/4 NPT)
② nut ⑤ armour clamp
③ backup ring ⑥ grommet (external sealing)

1/2 - 3/4 NPT,
for unarmoured cable

1/2 - 3/4 NPT,
for armoured cable

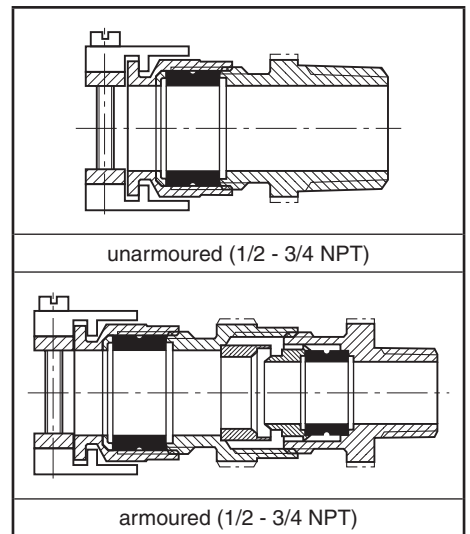

CONSTRUCTION

Adapter	Nickel-plated brass
Grommet	NBR
Breaker piece	Stainless steel

SAFETY CODE

Ex II 2 G Ex d IIC
II 2 D Ex tb IIIC

SPECIFICATIONS

pipe size	cable		type	catalogue number	
	outer diameter (mm)	inner diameter (mm)		unarmoured cable	armoured cable
1/2 NPT and 3/4 NPT versions					
1/2 NPT	-	7 to 12	01	88200011	-
	10 to 16	7 to 12	02	-	88200014
3/4 NPT	-	10 to 16	01	88200007	-
	13,5 to 21	13,5 to 20,5 10 to 15,5	01 02	88200010 -	- 88200013

ACCESSORIES

- 3/4 NPT to 1/2 NPT reducer, catalogue number: **88200012**
- Other cable glands on request

INSTALLATION

- The cable gland can be supplied pre-installed on Ex d enclosure

DIMENSIONS (mm), WEIGHT (kg)



TYPE 01
1/2 - 3/4 NPT
Unarmoured cable

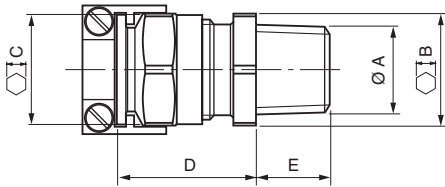

TYPE 02
1/2 - 3/4 NPT
Armoured cable

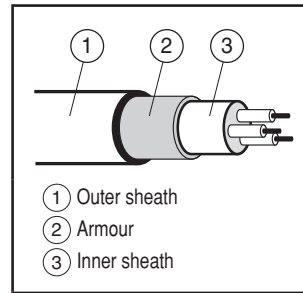
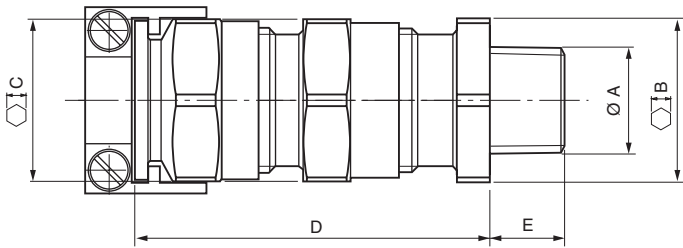

type	Ø A	B	C	D	E	weight
01	1/2 NPT	24	19	27,5	16	0,04
	3/4 NPT ⁽¹⁾	30	24	32	16	0,055
	3/4 NPT ⁽²⁾	30	30	26,5	16	0,07
02	1/2 NPT	24	24	51	16	0,09
	3/4 NPT	30	30	57	16	0,17

⁽¹⁾ Catalogue number: 88200007

⁽²⁾ Catalogue number: 88200010

All leaflets are available on: www.asco.com

28 - Explosionproof equipment



青岛秉诚自动化设备有限公司
地址：中国·青岛市重庆南路99号海尔云街甲3号楼7F

服务热线：4006-918-365
网址：http://www.asco.store

传真：(86-532)585-10-365
Email：sales@bechinas.com