

SPECIFICATIONS

FLUID	: air or neutral gas, filtered, lubricated or not
PORTS	: G 1/4
PRESSURE	: 0 to 10 bar
TEMPERATURE	: -25°C to +60°C
FLOW (Qv at 6 bar)	: 860 l/min (ANR)

CONSTRUCTION

Environmentally-protected construction
 Body: treaded aluminium
 Internal parts: zinc diecasting, steel,
 stainless steel, acetal (POM)
 Sealings: nitrile (NBR) and polyurethane (PUR)

For 3/2 NC connection
 1 = Pressure
 2 = Outlet
 3 = Exhaust



CHOICE OF EQUIPMENT

[Configurator - CAD Files](#)

Symbols functions	Operators		CODES
	Pilot	Return	
LEVER OPERATED			
	Lever - Lever detented		55102088
	Lever	Spring	55102089
PEDAL OPERATED			
	Pedal 2 positions		55102090
	Pedal	Spring	55102091
BUTTON OPERATED			
	Button	Spring	55102082
	Button push-pull		55102083

Note: do not connect the pressure supply to the exhaust port 3. For a "distributing" function or use in NO function, contact us.

These products exist in versions [5/2](#) and [5/3](#)

00403GB-2016/R01
Availability, design and specifications are subject to change without notice. All rights reserved.

All leaflets are available on: www.asco.com

DIMENSIONS AND WEIGHTS

VALVE LEVER OPERATED

Weight: 0,360 kg

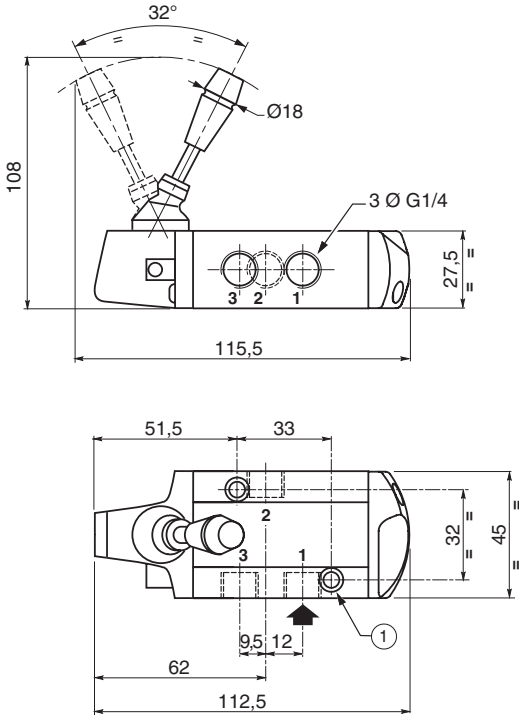

[Configurator - CAD Files](#)

VALVE PEDAL OPERATED

Weight: 0,515 kg

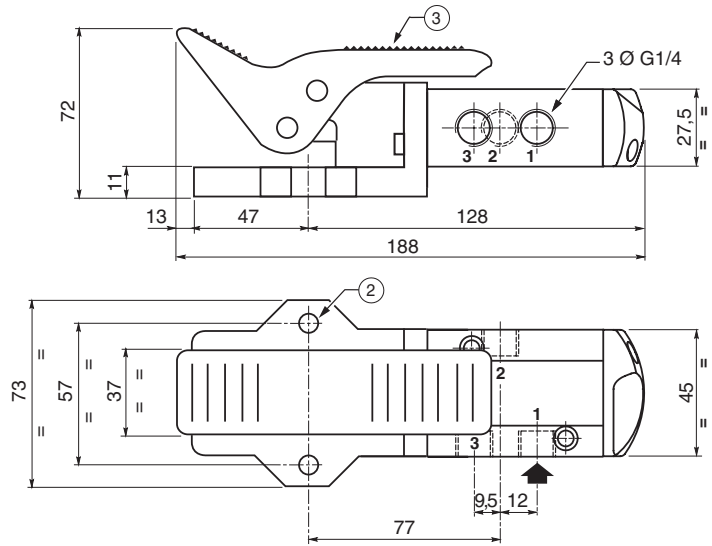

- ① 2 fixing holes : Ø 5,3 - counterbore : Ø 9, dept 5
- ② 2 fixing holes : Ø 8,5
- ③ Return pedal 2 positions

BUTTON

BUTTON PUSH-PULL

Weight: 0,230 kg

