

## SPECIFICATIONS

FLUID	: Air or neutral gas, filtered, lubricated or not
PORTS	: G 1/4
PRESSURE	: 0 to 10 bar
TEMPERATURE	: -25°C to +60°C
FLOW (Qv at 6 bar)	: 860 l/min (ANR)

## CONSTRUCTION

Environmentally-protected construction  
Spool valve  
Body: treated aluminium  
Internal parts: zinc diecasting, steel, stainless steel, acetal (POM)  
Seals: NBR (nitrile) and PUR (polyurethane)



1	= Pressure
2,4	= Outlets
3,5	= Exhausts

## CHOICE OF EQUIPMENT

[Configurator - CAD Files](#)

Type	Pilot	Return	Operating effort (daN)	CODES
<b>3/2</b> 	Roller	Spring	4,8	<b>55102084</b>
<b>5/2</b> 	Roller	Spring	4,8	<b>55102087</b>

Note: do not connect the pressure supply to the exhaust port 3. For a "distributing" function or use in NO function, contact us.

**DIMENSIONS AND WEIGHTS**  
ROLLER

[Configurator - CAD Files](#)

**3/2**

Weight: 0,250 kg

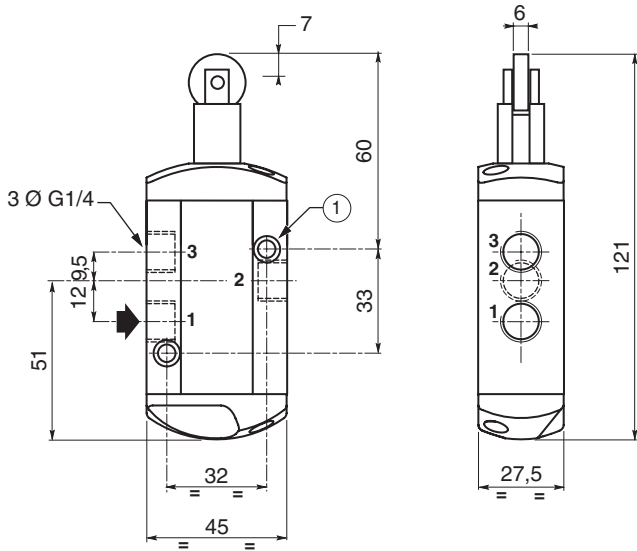

**5/2**

Weight: 0,285 kg

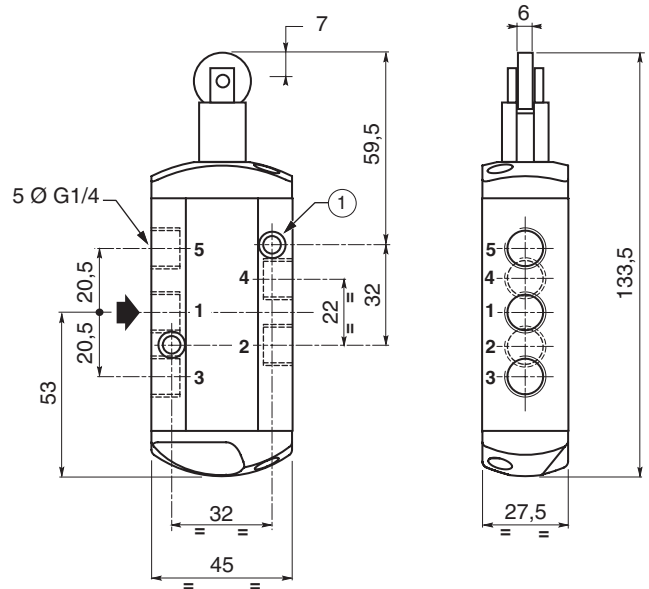

① 2 fixing holes: Ø 5,3 - counterbore : Ø 9, dept 5

Cam angles

Maximum speed: 0,3 m/s

