

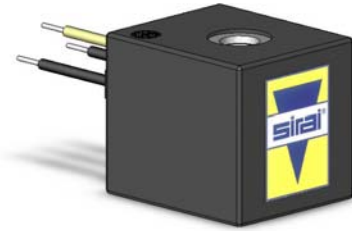

# COIL Flying leads

# Z135A – Z138A

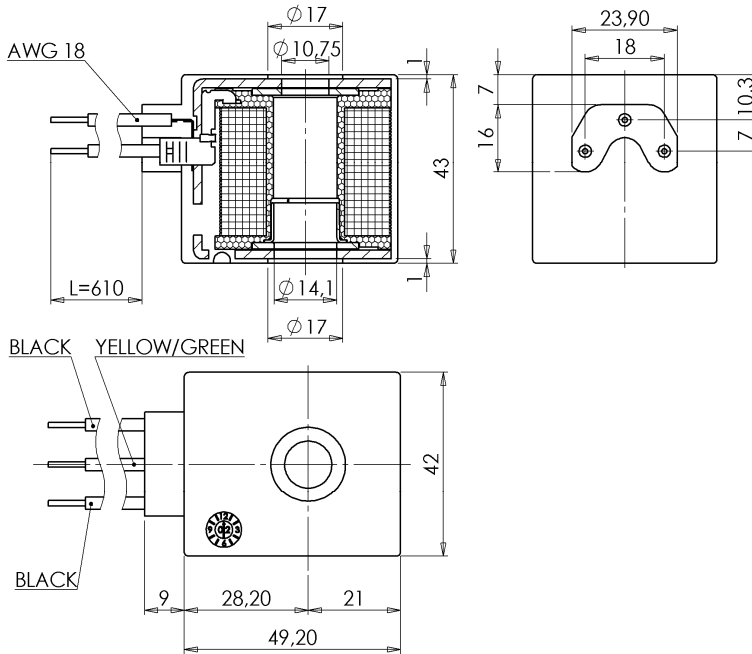

### ► GENERAL FEATURES

Complying with 2014/35/EU (LVD) and 2014/30/EU (EMC) directives.  
Product in accordance with the RoHS 2 directive.  
100% inspected.

### ► ELECTRIC CONNECTIONS

N° 3 wires AWG 18 (2 line + earth), length 610mm

### ► ENCAPSULATION MATERIALS

PET (polyethylene terephthalate) fiberglass reinforced; black colour

### ► TECHNICAL FEATURES

<i>Continuous duty</i>	ED 100%
<i>Insulation class</i>	Z135A: F (140°C) Z138A: H (165°C)
<i>Ambient temperature</i>	Z135A: -10°C +60°C Z138A: -10°C +80°C.
<i>Protection degree</i>	IP 65 (EN 60529)
<i>Voltages</i>	DC 12-24V (+10% -5%) AC 24V/50Hz – 110V/50Hz (120V/60Hz) - 230V/50Hz (+10% -15%) (Other voltages and frequencies on request).

TYPE	POWER ABSORPTION			NOTES	WEIGHT (kg)
	AC (VA)		DC (W)		
	Inrush	Holding			
Z135A	44	26	13	1	0,320
Z138A				2	

### ► NOTES

1 - UL approval – F class (E153691).  
2 - UL approval – H class (E153691).

THE VALIDITY OF REPORTED DATA IS REFERRED TO THE DATE OF ISSUE. POSSIBLE UPDATES ARE AVAILABLE ON REQUEST.

09/2/1606

