

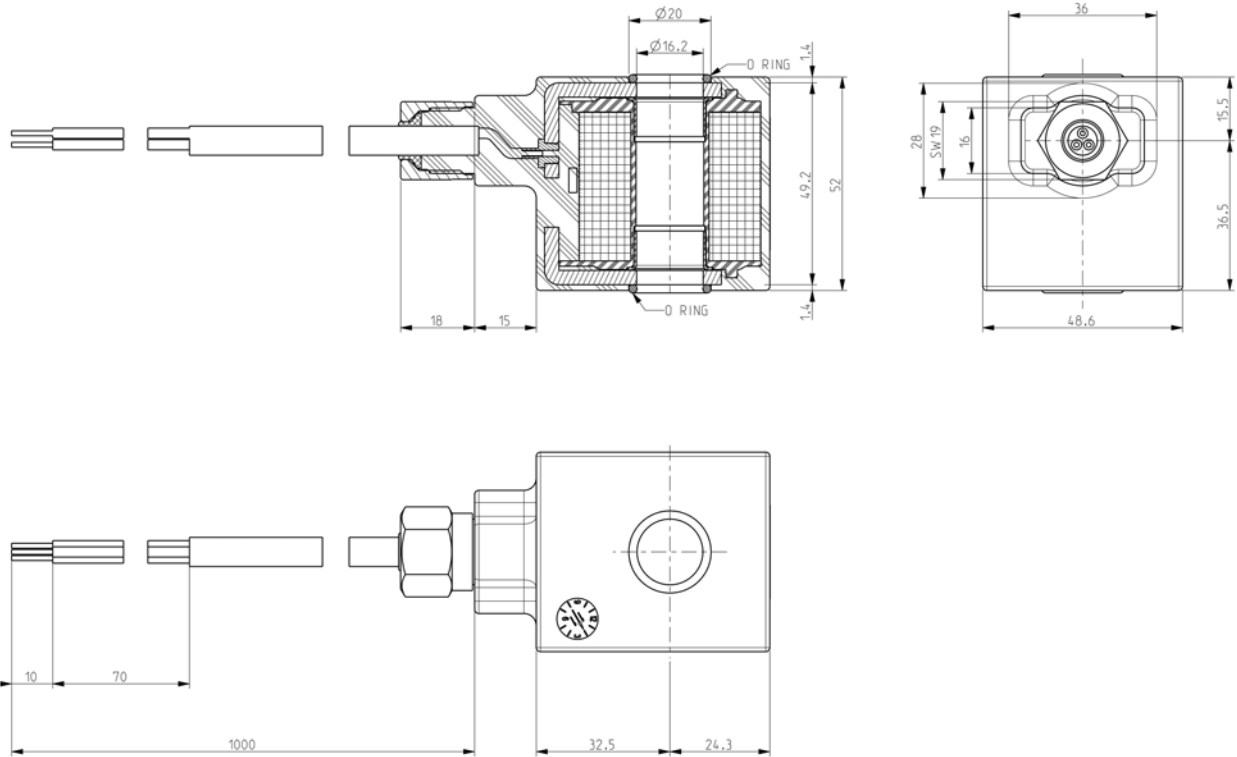

COIL
Cable 3x1mm²

Z917G



► GENERAL FEATURES

Complying with 2014/35/EU (LVD) and 2014/30/EU (EMC) directives.
Product in accordance with the RoHS 2 directive.
100% inspected.

► ELECTRIC CONNECTIONS

Cable with 3 wires x 1mm² molded in XLPO
Length 1000mm

► ENCAPSULATION MATERIALS

PBT (polybutylene terephthalate) fiberglass reinforced (black colour)

► TECHNICAL FEATURES

Duty ED 60% - max. cycle time 40min
Insulation class F (140°C)
Ambient temperature -10°C +60°C
Protection degree IP 67 (EN 60529)
Voltages AC 24V/50Hz-110V/50Hz (120V/60Hz)
230V/50Hz (+10% -15%)

TYPE	POWER ABSORPTION			NOTES	WEIGHT (kg)
	AC (VA)		DC (W)		
	Inrush	Holding			
Z917G	150	46	-	-	0,600

THE VALIDITY OF REPORTED DATA IS REFERRED TO THE DATE OF ISSUE. POSSIBLE UPDATES ARE AVAILABLE ON REQUEST.

1302/1606

