

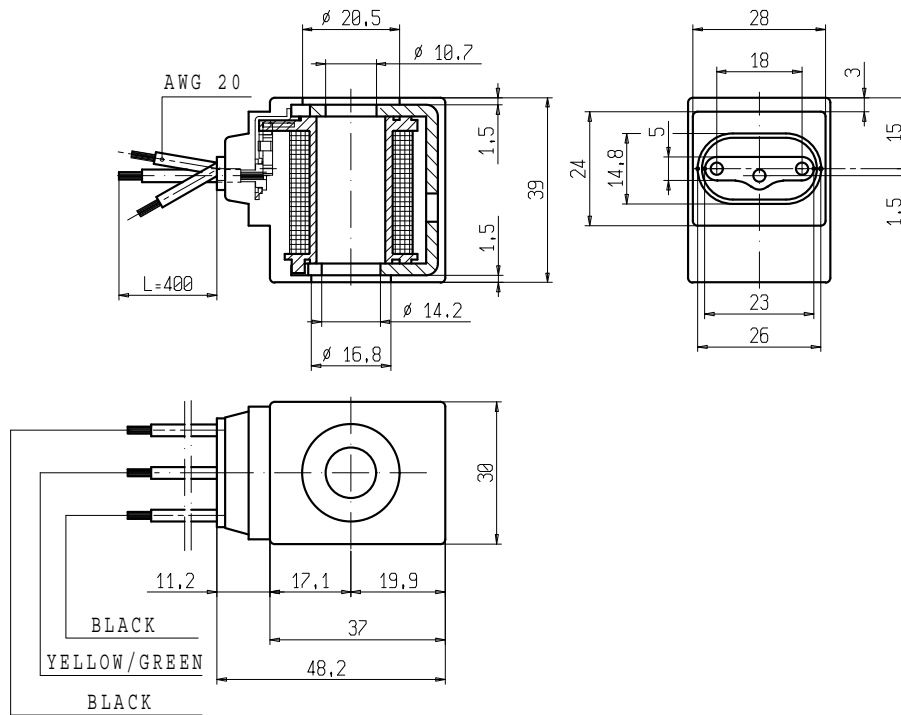

COIL Flying leads

ZA35A



► GENERAL FEATURES

Complying with 2014/35/EU (LVD) and 2014/30/EU (EMC) directives.
Product in accordance with the RoHS 2 directive.
100% inspected.

► ELECTRIC CONNECTIONS

- N° 3 wires AWG 20 (2 line + earth), length 400mm.

► ENCAPSULATION MATERIALS

PET (polyethylene terephthalate) fiberglass reinforced (black colour)

► TECHNICAL FEATURES

<i>Continuous duty</i>	ED 100%
<i>Insulation class</i>	F (155°C)
<i>Ambient temperature</i>	-10°C +60°C
<i>Protection degree</i>	IP 66 (EN 60529)
<i>Voltages DC</i>	12-24V (+10% -5%)
<i>AC</i>	24V/50Hz – 110V/50Hz (120V/60Hz) - 230V/50Hz (+10% -15%) (Other voltages and frequencies on request)

TYPE	POWER ABSORPTION			NOTES	WEIGHT (kg)
	AC (VA)		DC (W)		
	Inrush	Holding			
ZA35A	23	14	9	-	0,145

THE VALIDITY OF REPORTED DATA IS REFERRED TO THE DATE OF ISSUE. POSSIBLE UPDATES ARE AVAILABLE ON REQUEST.

0804/1606

