

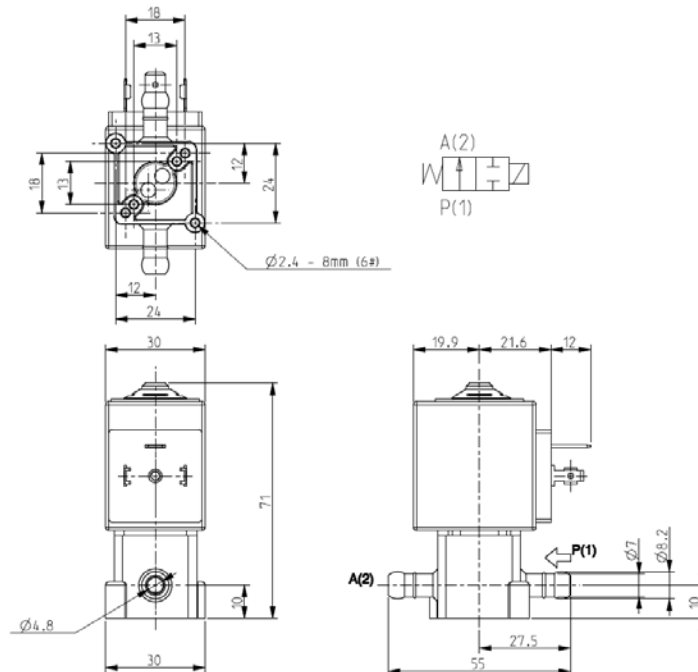

SOLENOID VALVE
2/2 - NC (Normally closed)
 Direct acting
 Barbed ports

L123V04



► **GENERAL FEATURES**

Direct acting solenoid valve.
 Suitable to shut off liquid and gaseous fluids; suitable for low pressure steam and applications in sterilising autoclaves (verify the compatibility of fluid with materials in contact).

► **TECHNICAL FEATURES**

Maximum allowable pressure (PS) 10 bar
 Opening time ~20ms
 Closing time ~20ms
 Fluid temperature 0°C +130°C
 Max viscosity 5°E (~37 cStokes or mm²/s)

► **MATERIALS IN CONTACT WITH FLUID**

Body PPS
 Sealing FPM
 Internal components Stainless steel
 Seat PPS
 Guide assembly Stainless steel
 Shading ring Copper

► **COIL**

Approval UL (class F) – for UL cl.H: ZA34
 Continuous duty ED 100%
 Encapsulation material PPS (Polyphenylsulfure) fiberglass reinforced
 Coil insulation class F (155°C) on request class H (180°C)
 Ambient temperature -10°C +50°C
 Electric connections DIN 46340 - 3 poles connectors (EN175301-803)
 Protection degree IP 67 (EN 60529) with plug connector
 Voltages DC 12-24V (+10% -5%)
 AC 24V/50Hz - 110V/50Hz (120V/60Hz) - 230V/50Hz (+10% -15%)
 (Other voltages and frequencies on request).

Port size	Orifice size (mm)	Differential pressure (bar)				Kv (m ³ /h)	Series and type		Power absorption			Sealings	Notes	Weight (kg)
		Δp min	Δp max		Valve		Coil	AC (VA)		DC (W)				
			Gases	Liquids				Inrush	Holding					
			AC	DC	AC	DC								
Barbed ports	2,3	0	10	10	10	10	L123V04	ZA10A	23	14	9	FPM	1-2	0,210
	3,2		10	4	10	4								

► **NOTES**

- Sealings : FPM = Fluoro-carbon elastomer
- IMQ CSV approval, see ZA10 datasheet for further details
- UL approved coil (E153691)
- 1 - Only for use with steam, consider following values: PSmax 2,8 bar (max fluid temperature 130°)
- 2 - The pressure values shown in the table refer to the potential of the valve: they can be lower depending on the connection system used



► SPARE PARTS

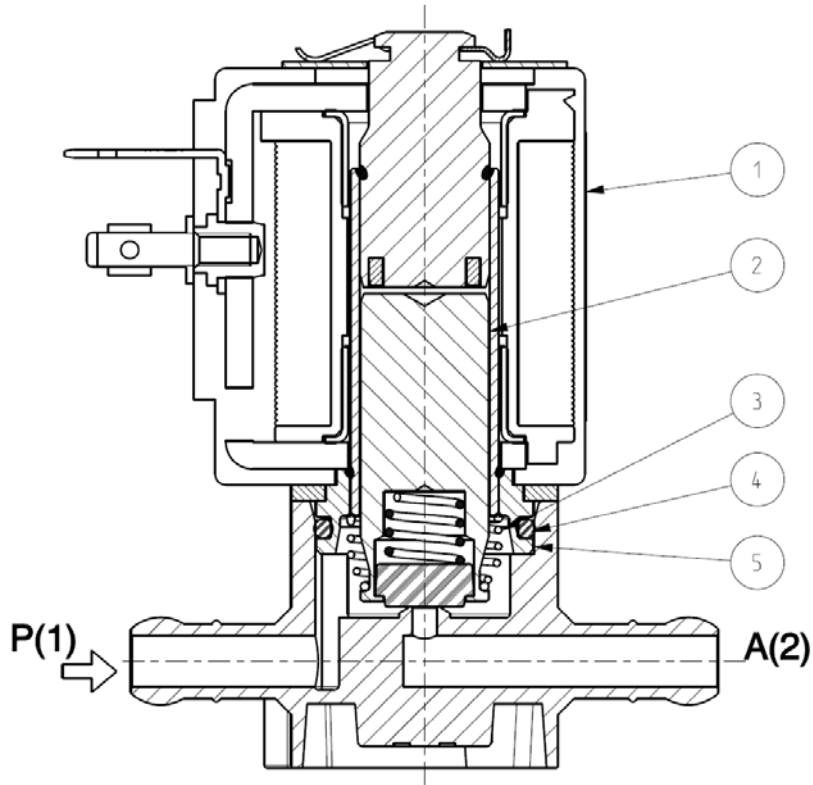

Kit description	Kit P.N.	Consisting of:
Core kit	G3139401	Core pos. 2
Core return spring kit	G3022401	N.10 core return spring pos. 3
O-Ring guide assembly kit	GU2428000017	N.10 O-Ring guide assembly pos. 4
Guide assembly kit	G31487	Guide assembly pos. 5 Coil clip
Coil	ZA10A	Coil pos.1

► MOUNTING

- Solenoid valve can be mounted in any position; vertical with coil upwards preferred.
- In case of disassembling for usual maintenance, the fixing screws of the guide assembly have to be tightened with 0,6±0,7 Nm torque.