

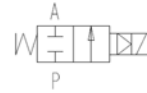

**SOLENOID VALVE**  
**2/2 - NC (Normally closed)**  
 Pilot operated  
**G1 ¼ ÷ 2**

**L182-BIG**

G 1" ¼ ÷ 2"

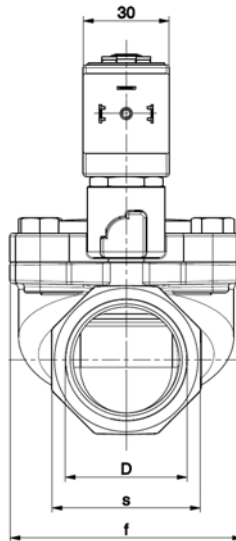
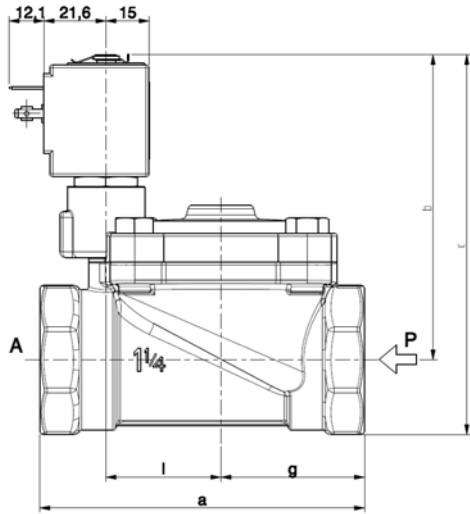

D	a	b	c	f	g	l	s
G 1 ¼	113	106	132	81	50	40	52
G 1 ½	140	110	140	110	64	53	60
G 2	157	114	150	110	72	53	72

► **GENERAL FEATURES**

Diaphragm valve, pilot operated, having full orifice.  
 Suitable to shut off liquid and gaseous fluids (verify the compatibility of fluid with materials in contact).  
 Not suitable for use with dangerous fluids listed in Group 1, therefore they are free from CE marking in conformity with article 3 § 3 of the European Directive 97/23/EC (Pressure Equipment Directive).

► **MATERIALS IN CONTACT WITH FLUID**

*Body* Brass  
*Sealing* Diaphragm: NBR or FPM / Actuator: FPM  
*Internal components* Brass and stainless steel  
*Seat* Brass  
*Guide assembly* Stainless steel  
*Shading ring* Copper

► **TECHNICAL FEATURES**

*Maximum allowable pressure (PS)* 15 bar

Response times	1 1/4	1 1/2	2
<i>Opening time (ms)</i>	100	360	360
<i>Closing time (ms)</i>	650	650	650

*Fluid temperature* -10°C +90°C (NBR)  
 0°C +130°C (FPM)  
*Max viscosity* 5°E (~37 cStokes or mm<sup>2</sup>/s)

► **COIL**

*Approval* UL (class F) – for UL cl.H: ZA34  
*Continuous duty* ED 100%  
*Encapsulation material* PPS (Polyphenylsulfure) fiberglass reinforced  
*Coil insulation class* F (155°C) on request class H (180°C)  
*Ambient temperature* -10°C +50°C  
*Electric connections* DIN 46340 - 3 poles connectors (EN175301-803)  
*Protection degree* IP 67 (EN 60529) with plug connector  
*Voltages* DC 12-24V (+10% -5%)  
 AC 24V/50Hz - 110V/50Hz (120V/60Hz) - 230V/50Hz (+10% -15%)  
 (Other voltages and frequencies on request)

Port size ISO 228	Orifice size. (mm)	Differential pressure (bar)				Kv (m <sup>3</sup> /h)	Series and type			Power absorption			Sealings	Notes	Weight (kg)
		Δp min	Δp max		Valve		Valve with manual override	Coil	AC (VA)		DC (W)				
			Gases	Liquids					Inrush	Holding					
G 1 ¼	30	0,50	10	10	10	15	L182B48	L182B49	ZA10A	23	14	9	NBR (diaphragm) FPM (actuator)	-	1,590
G 1 ½	45														2,510
G 2	45														2,990
G 1 ¼	30														1,590
G 1 ½	45														2,510
G 2	45														2,990

► **NOTES**

- Sealings : NBR = Nitrile-butylene elastomer FPM = Fluoro-carbon elastomer
- Operation with gaseous fluids at high pressure without any outlet restriction can reduce the diaphragm life.
- IMQ CSV approval, see ZA10 datasheet for further details
- UL approved coil (E153691)



# L182-BIG G 1" ¼ ÷ 2"

## ► SPARE PARTS

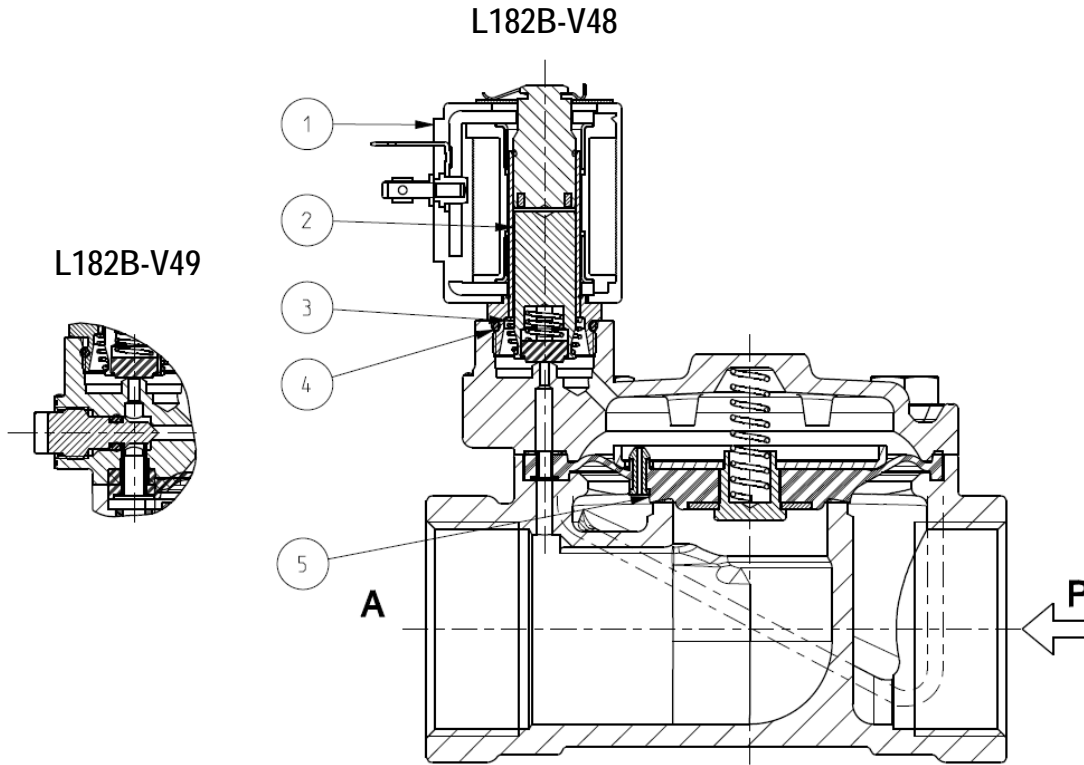

### Kit description

Core kit

Kit P.N.

G3146801

Consisting of:

Core pos. 2  
Core return spring pos. 3  
OR guide assembly pos. 4

Diaphragm kit

L182B..	G 1 ¼	2400801R
	G1 ½ - 2	2401301R
L182V..	G 1 ¼	2400802R
	G1 ½ - 2	2401302R

Diaphragm assembly pos. 5

Coil

ZA10A

Coil pos. 1

## ► MOUNTING

Solenoid valve can be mounted in any position; vertical with coil upwards preferred.

THE VALIDITY OF REPORTED DATA IS REFERRED TO THE DATE OF ISSUE. POSSIBLE UPDATES ARE AVAILABLE ON REQUEST.