

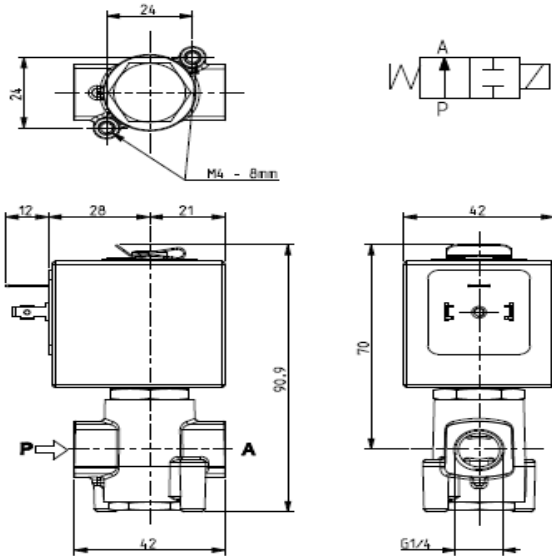

**SOLENOID VALVE**  
**2/2 - NO (Normally open)**  
**Direct acting**  
**G 1/4**

**L256**



► **GENERAL FEATURES**

Direct acting solenoid valve, suitable for vacuum at port "P" (PA – PP = 1 bar)  
 Suitable to shut off liquid and gaseous fluids (verify the compatibility of fluid with materials in contact).

► **TECHNICAL FEATURES**

Maximum allowable pressure (PS) 40 bar  
 Opening time ~30ms  
 Closing time ~30ms  
 Fluid temperature -10°C +170°C (stainless steel)  
 0°C +130°C (FPM)  
 Max viscosity 5°E (~37 cStokes or mm<sup>2</sup>/s)

► **MATERIALS IN CONTACT WITH FLUID**

Body Brass  
 Sealing Stainless steel or FPM  
 Internal components Stainless steel  
 Seat Brass or stainless steel  
 Core tube Stainless steel  
 Shading coil Copper

► **COIL**

Continuous duty ED 100%  
 Encapsulation material PET (polyethylene terephthalate) fiberglass reinforced  
 Insulation class F (140°C) on request class H (165°C) - UL  
 Ambient temperature -10°C +60°C  
 Electric connections DIN 46340 - 3 poles connectors (DIN 43650)  
 Protection degree IP 65 (EN 60529) with plug connector  
 Voltages DC 12-24V (+10% -5%)  
 AC 24V/50Hz - 110V/50Hz (120V/60Hz) - 230V/50Hz (+10% -15%)  
 (Other voltages and frequencies on request)

Port size ISO 228	Orifice size (mm)	Differential pressure (bar)				Kv (m <sup>3</sup> /h)	Series and type		Power absorption			Sealings	Function Notes	Weight (kg)	
		Δp min	Δp max				Valve	Coil	AC (VA)		DC (W)				
			Gases		Liquids				Inrush	Holding					
			AC	DC	AC										DC
G 1/4	3	0	-	-	30	30	0,22	L256M02	44	24	13	Stainless steel	1 – 2 – 3	0,535	
	3,2		12	12	10	10	0,30	L256V01							Z130A
	4,5		5	5	4	4	0,45								

► **NOTES**

- Sealings : FPM = Fluoro-carbon elastomer
- 1 - Stainless steel seat. Particularly suitable for hydraulic and fuel oils.
- 2 - On request coil type Z134A, class "H" (+165°C) maximum ambient temperature +80°C – UL approval.
- 3 - OR between core armature and body in FPM.

0705/1707



► SPARE PARTS

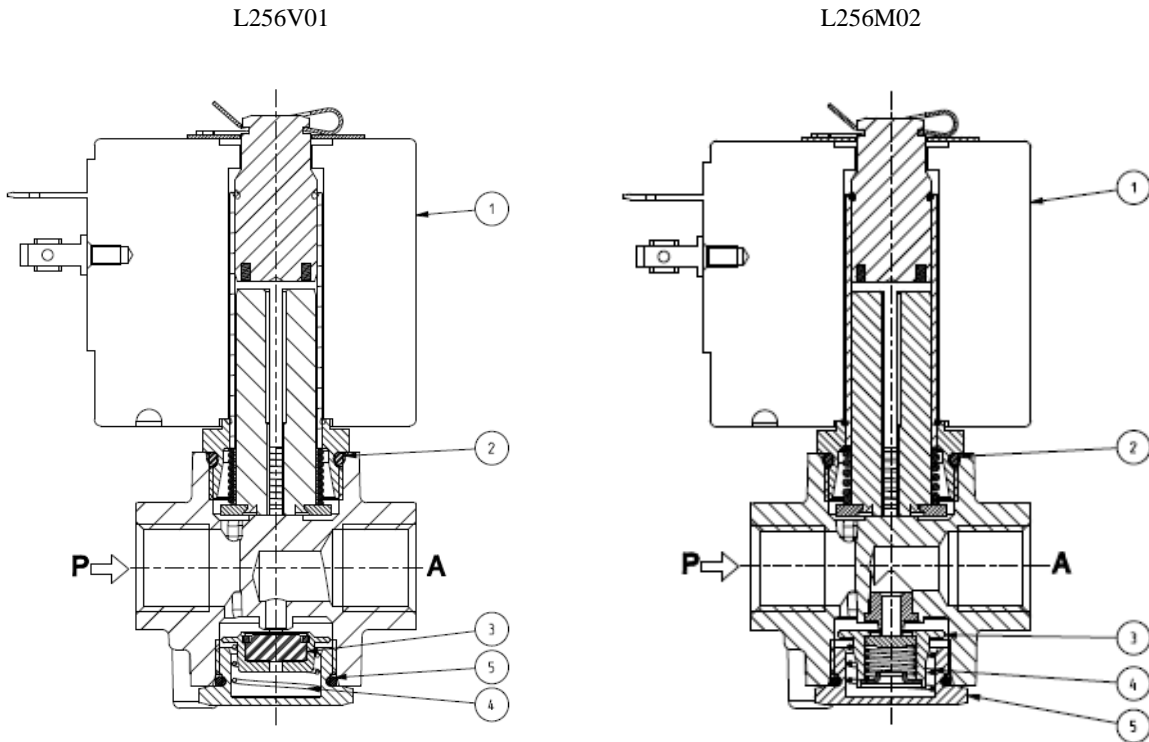

Kit description

Core sealing assembly kit

L256M02  
L256V01 Ø 3,2  
L256V01 Ø 4,5

OR guide assembly kit

OR cap kit

Coil

Kit P.N.

G3093201  
G3093101  
G 3093104

GU242400017

GU2424000155

Z130A

Consisting of:

Sealing group pos.3  
Sealing return spring pos.4  
OR cap pos. 5

N°.10 OR guide assembly pos. 2

N°.10 OR cap pos.5

Coil pos.1

► INSTALLATION

Solenoid valve can be mounted in any position; vertical with coil upwards preferred.

THE VALIDITY OF REPORTED DATA IS REFERRED TO THE DATE OF ISSUE. POSSIBLE UPDATES ARE AVAILABLE ON REQUEST.