

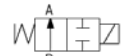

SOLENOID VALVE
2/2 - NO (Normally open)
Direct acting
G1/4 - Barbed ports

L257V04-V05

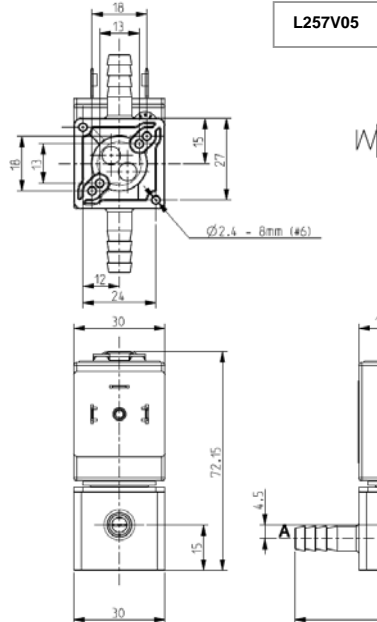
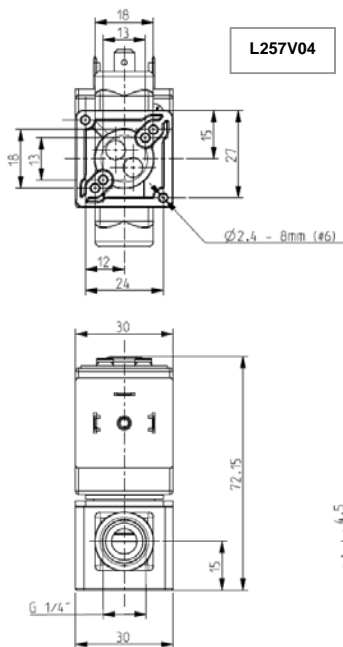

► GENERAL FEATURES

Direct acting solenoid valve, suitable for vacuum at port "P"
 (PA – PP = max 1 bar).
 Suitable to shut off liquid and gaseous fluids; suitable for low pressure steam and applications in sterilising autoclaves (verify the compatibility of fluid with materials in contact).

► TECHNICAL FEATURES

Maximum allowable pressure (PS)	10 bar
Opening time	~20ms
Closing time	~20ms
Fluid temperature	0°C +130°C
Max viscosity	5°E (~37 cStokes or mm ² /s)

► MATERIALS IN CONTACT WITH FLUID

Body	PPS
Sealing	FPM
Internal components	Stainless steel and PPS
Seat	PPS
Core tube	Stainless steel
Shading coil	Copper

► COIL

Approval
 Continuous duty
 Encapsulation material
 Insulation class
 Ambient temperature
 Electric connections
 Protection degree
 Voltages DC

ZA10A	ZA10B
UL (class F) – for UL cl.H: ZA34	
ED 100%	
PPS (Polyphenylsulfure) fiberglass reinforced	PET (polyethylene-terephthalate) fiberglass reinforced
F (155°C) on request class H (180°C)	F (155°C)
-10°C +50°C	
DIN 46340 - 3 poles connectors (EN175301-803)	
IP 67 (EN 60529) with plug connector	IP65 (EN 60529) with plug connector
-	24V (+10% -5%) (UL)
24V/50Hz 110V/50Hz (120V/60Hz) 230V/50Hz (+10% -15%)	-

(Other voltages and frequencies on request)

Port size G=ISO 228	Orifice size (mm)	Differential pressure (bar)				Kv (m ³ /h)	Series and type		Power absorption			Sealings	Notes	Weight (kg)	
		Δp min	Δp max				Valve	Coil	AC (VA)		DC (W)				
			Gases	Liquids					Inrush	Holding					
G1/4	4,2	0	AC	DC	AC	DC	L257V04	ZA10A	23	14	-	FPM	1 - 2 - 3	0.220	
-			2,5	-	2,5	-		ZA10B	-	-	10				
BARBED PORTS			2,5	-	2,5	-	L257V05	ZA10A	23	14	-				
-			2,5	-	2,5	-		ZA10B	-	-	10				

► NOTES

- Sealings : FPM = Fluoro-carbon elastomer
- UL approved coil (E153691)
- 1 - IMQ CSV approval, see ZA10 datasheet for further details
- 2 - The pressure values shown in the table refer to the potential of the valve: they can be lower depending on the connection system used
- 3 - Maximum driving torque of the pipe fittings for thread connections = 2Nm



► SPARE PARTS

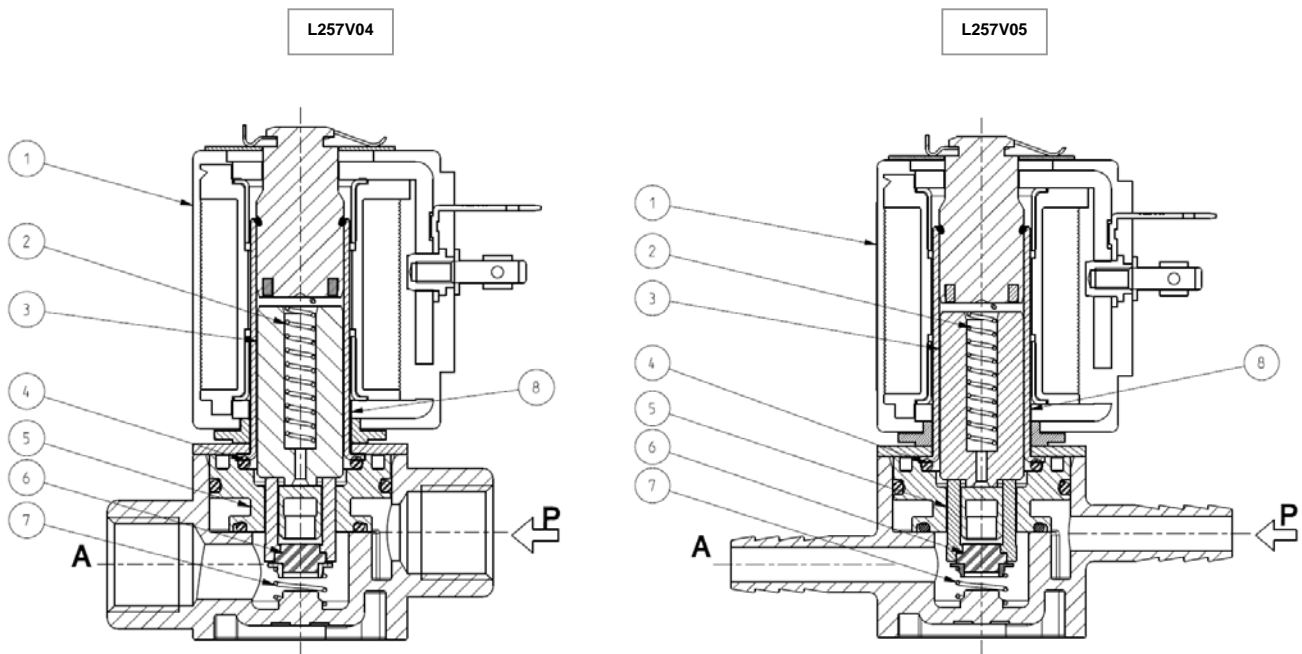

Kit description

Kit P.N.

Consisting of:

Core kit

G3138301

Core return spring pos. 2
Core pos. 3
O-Ring guide assembly pos.4
Pusher pos. 5
Sealing disc return spring pos. 7
Sealing disc pos. 6

Core return spring kit

G290513-001

N°.10 Core return spring pos. 2

O-Ring guide assembly kit

GU2428000015

N°. 10 OR guide assembly pos.4

Guide assembly kit

G31488

Guide assembly pos.8
Coil clip

Coil

ZA10A
ZA10B

Coil pos.1

► INSTALLATION

- Solenoid valve can be mounted in any position; vertical with coil upwards preferred.
- When using any sealant for fittings, please check its chemical compatibility with body material (PPS).
- In case of disassembling for usual maintenance, the fixing screws of the guide assembly have to be tightened with $0,6 \pm 0,7$ Nm torque.

THE VALIDITY OF REPORTED DATA IS REFERRED TO THE DATE OF ISSUE. POSSIBLE UPDATES ARE AVAILABLE ON REQUEST.