

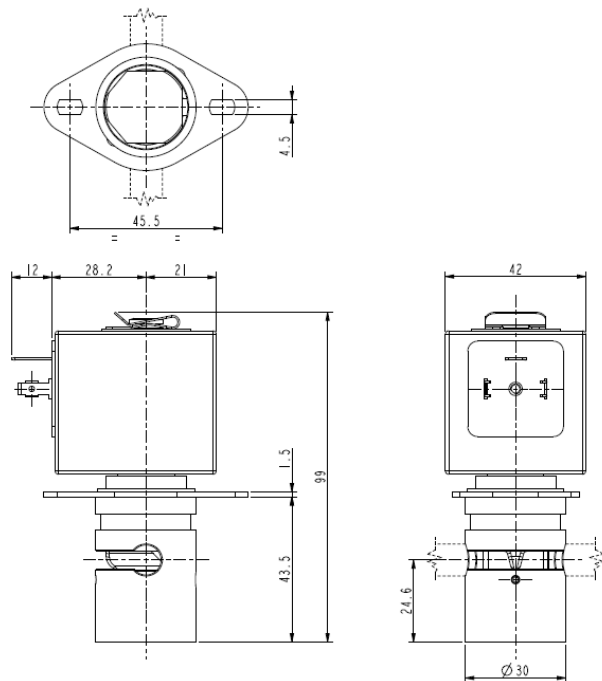

# PINCH SOLENOID VALVE 2/2 – NC (Normally closed)

S106



► **GENERAL FEATURES**

Pinch solenoid valve, suitable to shut off media without producing neither turbulent flows, nor dead spaces.  
High flow rate under the same conditions of internal diameter of different solenoid valves; the system allows a bi-directional through flow.  
The valves are suitable for soft SILICONE tubings or others, similar as to elasticity and hardness (50 shore A).  
**The tubing is the only material in contact with the fluid.**  
The tubings are not included in our supply.

► **INSTALLATION**

Solenoid valve can be mounted in any position.

► **MATERIALS**

<i>Body</i>	Anodized aluminum
<i>Pinching device</i>	POM (reinforced acetal copolymer)
<i>Internal components</i>	Stainless steel
<i>Core tube</i>	Stainless steel

► **COIL**

<i>Continuous duty</i>	ED 100%
<i>Encapsulation material</i>	PET (polyethylene terephthalate) fiberglass reinforced
<i>Insulation class</i>	F (140°C)
<i>Ambient temperature</i>	-10°C +60°C
<i>Electric connection</i>	DIN 46340 - 3 poles plug-connectors (EN175301-803)
<i>Protection degree</i>	IP 65 (DIN 40050) with plug-connectors
<i>Voltages</i>	DC 12-24V (+10% -5%) (Other voltages on request).

TUBINGS		Pinching strength (kg)	Series and type		Power absorption (W)	Notes	Weight (kg)
I.D. (mm)	O.D. (mm)		Valve	Coil			
4,8	7,9	1,100	S106-08	Z130A	13	-	0,440
6,4	9,5	1,400	S106-09				

► **NOTE**

- For the use of a soft tubing with outside diameter smaller than 6mm it is necessary to install the tubing guide sleeve (drawing K29501).
- In case the tubing is not placed in its seat, the solenoid valve could operate incorrectly.

THE VALIDITY OF REPORTED DATA IS REFERRED TO THE DATE OF ISSUE. POSSIBLE UPDATES ARE AVAILABLE ON REQUEST

0406/1301

