

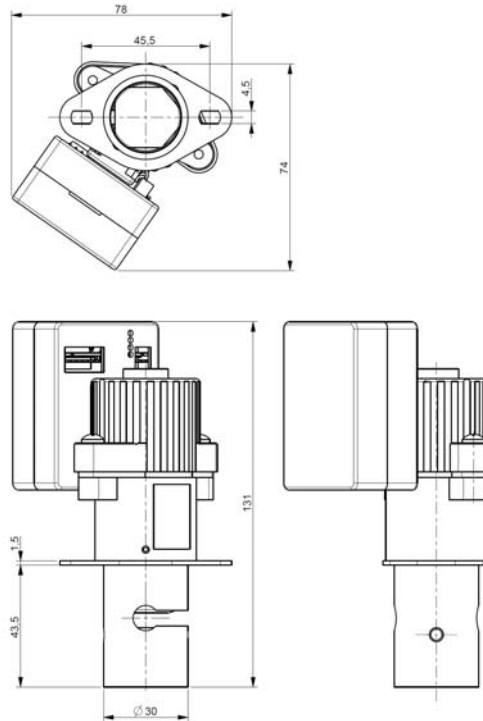

# STEPPER MOTOR PINCH VALVE 2-WAY ON - OFF FAIL SAVING

S170XA01X5900VU



## ► GENERAL FEATURES

Stepper motor pinch valve, suitable to shut off media without producing neither turbulent flows, nor dead spaces. Particularly suitable for most of the analytical, medical and food applications. The "OPEN" and "CLOSE" positions of the valve will be set as indicated in the section "OPERATING INSTRUCTIONS". The system allows a bi-directional through flow and a high flow rate. The valve is suitable for elastic tubings with hardness up to 90 Shore A. In case of loss of power, the valve will move to OPEN position.

The tubing (not included in our supply) is the only material in contact with the fluid.

## ► MATERIALS

Body	Anodized aluminium
Pinching device	POM (reinforced acetal copolymer)
Engine cover	PA (Polyamide)
Board cover	PA (Polyamide)

## ► ELECTRIC FEATURES

Power supply	[12÷24] V
Continuous duty	ED 100%
Minimum step	0.033mm/step
Insulation class	B (130°C)
Ambient temperature	-10°C +60°C
Electric connection	Molex pitch 2.54mm 6 pin Molex pitch 2.54mm 2 pin
Protection degree	IP 40 (EN 60529)

## ► LED INDICATIONS

Red	Alarm / Malfunction
Yellow	Valve closed
Green	Valve open
Blue	Programming mode

TUBINGS*		Pinching strength (N)	Opening/closing speed (mm/s)	Series and type	Power absorption (W)	Notes	Weight (kg)
Orifice size (mm)	MAX O.D. (mm)			Valve	In operation		
6,4	9,5	up to 80	3,33	S170XA01X5900VU	9	-	0.25

## ► NOTES

\* For use with different tubings, the min/max opening of the pinching device can be modified as indicated in the Maintenance Instructions. As an alternative, it is also possible to order the valves already programmed, with the desired strokes.

- Some data, e.g. actuating time and power absorption, are directly depending on the electronic control and can vary accordingly

THE VALIDITY OF REPORTED DATA IS REFERRED TO THE DATE OF ISSUE. POSSIBLE UPDATES ARE AVAILABLE ON REQUEST

1702



# S170XA01X5900VU

## ► CONNECTION

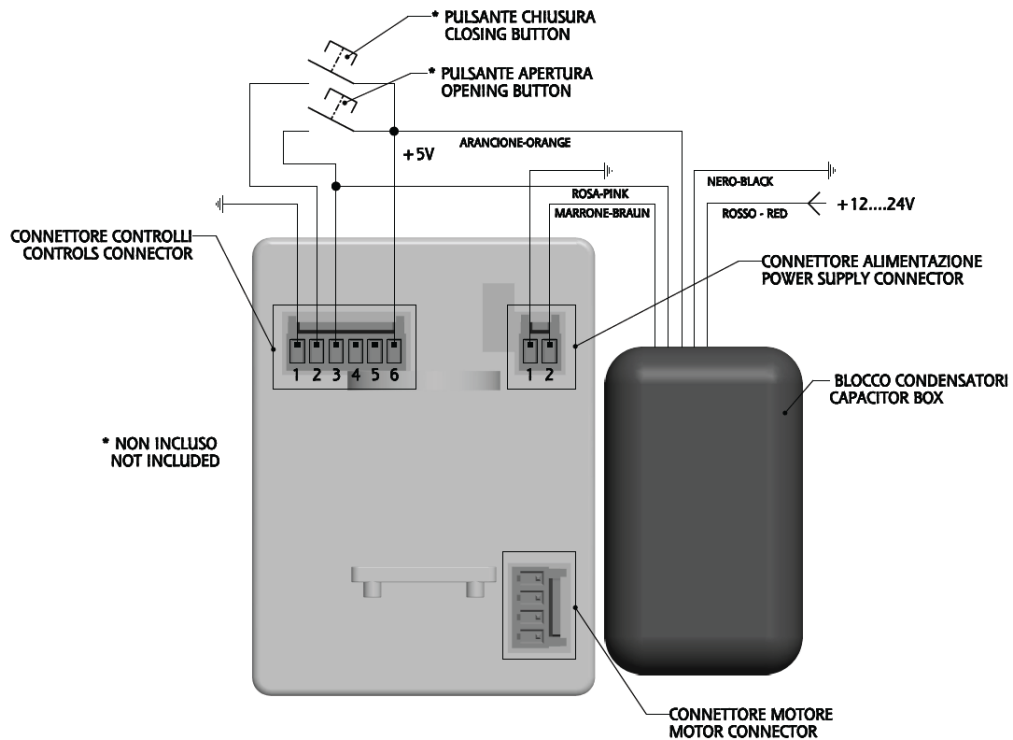

## ► OPERATING INSTRUCTIONS

When power is supplied, the valve will be in OPEN position (green LED on).

1. Insert the tube in the respective slot

The valve is now operational and by providing the opening or closing pulse (minimum 10ms), the valve will act accordingly.

LED signals meaning:

- Green LED on -> Valve open
- Yellow LED on -> Valve closed

### Note:

The valve, being normally open on loss of power (through the condenser block), will move to OPEN position.

THE VALIDITY OF REPORTED DATA IS REFERRED TO THE DATE OF ISSUE. POSSIBLE UPDATES ARE AVAILABLE ON REQUEST